

DOCUMENT RESUME

ED 239 820

RC 014 587

AUTHOR Bhola, H. S.; Bhola, Joginder K.  
 TITLE Program and Curriculum Development in the Post-Literacy Stages. (A Workshop Manual).  
 INSTITUTION German Foundation for International Development, Bonn (West Germany).  
 PUB DATE 80  
 NOTE 263p.; For related document, see SE 014 586.  
 PUB TYPE Guides - Non-Classroom Use (055)

EDRS PRICE MF01/PC11 Plus Postage.  
 DESCRIPTORS Adult Basic Education; Adult Literacy; Change Agents; Change Strategies; Community Development; Community Education; \*Curriculum Development; Definitions; \*Developing Nations; Foreign Countries; Functional Literacy; Illiteracy; \*Literacy Education; National Programs; \*Nonformal Education; Open Universities; \*Program Design; Rural Development; Rural Education; \*Staff Development; Workshops  
 IDENTIFIERS Asia (Southeast); India; \*Literacy Retention; Post Literacy Programs; Tanzania

ABSTRACT

The manual is intended for training workshops on program and curriculum development for the post-literacy stages, since many countries successful in literacy work find that even greater challenges await them as erstwhile illiterates emerge from literacy classes as new literates. The emphasis is on programs and curricula to help new literates retain literacy skills, strengthen those skills, and put literacy to work in their daily lives. The first chapter defines illiteracy, pre-literacy, and literacy, describes four types of illiterates: complete, functional, technological, and vocational, and discusses post-literacy stages, adult education, nonformal education, rural development, use of print and non-print media, and curriculum/program development. The second chapter catalogs post-literacy needs: literacy retention programs, second chance formal education, systematic integration between literacy and developmental objectives, and socialization for ideal societies. A third chapter, on program/curriculum design, discusses national goals, the change process, organizational design/institution building, needs analysis/community diagnosis, counselling/guidance for adult learners, program/curriculum design issues and skills, and personnel training for post-literacy programs. Technical appendices describe post-literacy work in Tanzania, India, and Southeast Asia; discuss organizational literacy for functional literacy workers and design of delivery systems for learning resources in community education; and give the project description of a curriculum/program development workshop. (MH)

\*\*\*\*\*  
 \* Reproductions supplied by EDRS are the best that can be made \*  
 \* from the original document. \*  
 \*\*\*\*\*

EDUCATIONAL

PROGRAM AND CURRICULUM DEVELOPMENT  
IN THE POST-LITERACY STAGES

(A Workshop Manual)

"PERMISSION TO REPRODUCE THIS  
MATERIAL HAS BEEN GRANTED BY

H. S. Bhola

TO THE EDUCATIONAL RESOURCES  
INFORMATION CENTER (ERIC)."

U.S. DEPARTMENT OF EDUCATION  
NATIONAL INSTITUTE OF EDUCATION  
EDUCATIONAL RESOURCES INFORMATION  
CENTER (ERIC)

✓ This document has been reproduced as  
received from the person or organization  
originating it.  
|| Minor changes have been made to improve  
reproduction quality.

• Points of view or opinions stated in this docu-  
ment do not necessarily represent official NIE  
position or policy.

By

H. S. Bhola  
Indiana University

with the Assistance of  
Joginder K. Bhola

1980



THE GERMAN FOUNDATION FOR INTERNATIONAL DEVELOPMENT

To the Five who made me a literacy worker--

Sohan Singh

Edgar Dale

Welthy H. Fisher

John W. Ryan, and

Josef Muller

TABLE OF CONTENTS

	Page
PREFACE . . . . .	v
I. TASKS AND THEIR CONTEXT . . . . .	1
II. A CATALOG OF NEEDS IN THE POST-LITERACY STAGES. .	12
Programs for Literacy Retention . . . . .	21
Second Chance Formal Education . . . . .	55
Systemic Integration Between Literacy and Developmental Objectives . . . . .	75
Socialization for the Ideal Society . . . . .	88
III. PROGRAM AND CURRICULUM DESIGN: A PRACTICAL MEMORANDUM TO PLANNERS AND IMPLEMENTERS . . . . .	104
Grasping the National Vision . . . . .	107
Understanding the Change Process . . . . .	110
Organizational Design and Institution Building .	115
Needs Analysis and Community Diagnosis . . . . .	118
Counselling and Guidance for Adult Learners . . . .	119
Program and Curriculum Design Issues and Skills .	123
Evaluation in the Post-Literacy Stages . . . . .	128
Training of Personnel for Planning and Implementation of Post-Literacy Programs . . . .	134
TECHNICAL APPENDICES	
Appendix A: Post-Literacy Activities in Tanzania . . . . .	140
Appendix B: Preliminary Report of the National Board of Adult Education's Committee on Post-Literacy and Follow-up Programmes . . . . .	148
Appendix C: No More Schools? . . . . .	160

|

Appendix D: Some Introductory Lessons on 'Organizational Literacy' for Functional Literacy Workers . . . . .	164
Appendix E: Notes on a Polyvariant Center and the Danish Folk High Schools . . . . .	194
Appendix F: Learning Resources for Community Education: Design Notes on Delivery Systems .	204
Appendix G: Project Description of a Workshop on Curriculum and Program Development for Post-Literacy Stages . . . . .	245

## PREFACE

This is a workshop manual prepared for use in training workshops dealing with program and curriculum development in the post-literacy stages. It will find its first use in a workshop on the subject being held in Arusha, Tanzania, during June 2-14, 1980.

The Arusha workshop being hosted by the Department of Adult Education, Ministry of National Education of the Government of Tanzania is part of a series of workshops sponsored by the German Foundation for International Development (DSE) in Africa. These workshops are based on the belief that administrators and practitioners working on literacy and nonformal education programs, both for governments and voluntary agencies, should be assisted through practical training related to their daily tasks to do a better job of implementing ongoing programs.

Two main themes have been covered in these workshops so far: (1) evaluation of literacy programs, and (2) curriculum development in literacy and nonformal education programs. To date, six workshops have been conducted in these different countries of East and Southern Africa:

### On the evaluation of functional literacy

Tanzania	December	1976
Kenya	May	1977
Zambia	July	1978
Kenya	May	1979

On curriculum development in functional literacy  
and nonformal education

Zambia	May	1979
Kenya	August	1979.

While the earlier workshops were somewhat general in content, the more recent ones are becoming specialized and focussed. For example, the Kenya workshop on evaluation held in May 1979 in Kericho, Kenya specialized in the evaluation of the effectiveness of development training programs. The forthcoming workshop in Arusha, Tanzania will be focussed on the special problems of programming and curriculum development in the post-literacy stages.

The topic of the Arusha workshop--Programming and Curriculum Development in the Post-Literacy Stages--is indeed an important one. More and more countries which have met successes in their literacy work are finding that even greater challenges await them as the erstwhile illiterates come out of literacy classes as new literates. Programs and curricula have to be designed for them to help them retain their newly acquired literacy skills, to strengthen those skills further and to put literacy to work in their daily lives.

Tanzania, it must be admitted, does not need an introduction to the subject of planning post-literacy programs. Among the countries that have conducted literacy campaigns in the last decade, Tanzania is without a doubt one country that has done the most experimenting with post-literacy programs

and has acquired the most experience. Our task at the workshop will thus be not to inform but to review, not to teach but to challenge. Hopefully, we will be able to expose to the view of Tanzanian literacy workers some new possibilities; and will certainly reinforce many of the initiatives already taken. More importantly, the workshop will be able to evaluate and systematize available experience for transfer to other countries engaged in program development in the post-literacy stages.

Some of those using this workshop manual are perhaps aware of the interconnection between the DSE's series of Africa workshops and the series of training monographs commissioned by the Unesco/Iranian International Institute for Adult Literacy Methods (IIALM). The following eight training monographs have already been published: The use of radio in adult literacy education, by Richard C. Burke; Programmed instruction for literacy workers, by S. Thiagarajan; Learning to read and reading to learn: an approach to a system of literacy instruction, by Sohan Singh; The ABCs of literacy: lessons from linguistics, by Kenneth L. Baucom; Visual literacy in communication: designing for development, by Anne Zimmer and Fred Zimmer; Towards scientific literacy, by Frederick J. Thomas and Allan K. Kondo; Evaluating functional literacy, by H. S. Bhoja; and Games and simulations in literacy training, by David R. Evans.

The DSE workshops have typically been built upon the



IIALM monograph series; and these workshops have, in turn, provided opportunities for testing the IIALM monographs before they were finally published. We have called the present document "a workshop manual" rather than a monograph to point up the tentative nature of some of the ideas presented here and to underline the unfinished state of this document. After a few test-in-use workshops such as the one in Arusha in June 1980, we hope this workshop manual will grow into a monograph on the subject of programming and curriculum development in the post-literacy stages.

In the meantime, we suggest that this manual be read together with an earlier document, Curriculum Development for Functional Literacy and Nonformal Education Programs, by H. S. Bhola, copies of which are available on request to literacy workers in developing countries from Dr. Josef Muller, Education and Science Branch, The German Foundation for International Development, Simrockstrasse 1, 5300 Bonn, West Germany. Comments on the present workshop manual sent to the author will be gratefully received.

Indiana University  
Bloomington, Indiana

H. S. Bhola

## CHAPTER I

### POST-LITERACY WORK: DEFINITIONS, TASKS, AND CONTEXT

---

#### Organization of the chapter

#### Illiteracy to post-literacy

- Illiteracy
- Pre-literacy
- Literacy
- Post-literacy stages

#### Post-literacy, adult education, nonformal education and rural development

- Adult education
- Nonformal education
- Rural development

#### The use of print and nonprint media

- A caution

#### Curriculum development

#### Program development

#### Summary

#### Things to do or think about

#### Readings and references

---

This is a manual on the subject of program development and curriculum development in the post-literacy stages. We must begin by explaining these terms:

#### Illiteracy to post-literacy

Literacy workers have seen a man's or a woman's

journey from illiteracy, through literacy, to independent learning, as consisting of many stages. Examine the following line:

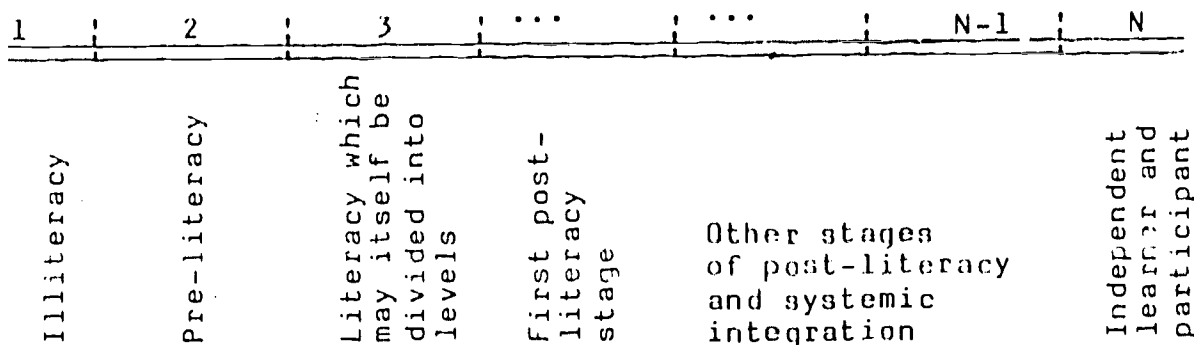

Illiteracy. The individual man or woman in this stage does not have any ability to read or write. Moreover, he or she does not even have any interest in becoming literate. The world of literacy is an alien world to the illiterate. The gap between the two worlds of illiteracy and literacy seems too wide; and there seems to be no advantage in trying to be literate.

Pre-literacy. In the pre-literacy stage, the illiterate individual is still unable to read and write but he or she is being brought in contact with the world of information. The understanding is slowly emerging that there is information out there which might be helpful in solving the problems of day-to-day life. To begin with, this information comes to the illiterate individual through nonprint media, but the important thing is that information consumption through media is creating motivations for wanting to become

literate and an independent consumer of information.

Literacy. Literacy is defined as the ability to read and write in the mother tongue. (In some circumstances, it is defined as the ability to read and write in a national or even an international language.) We know, of course, that among a group of literate youth or adults, some can have better literacy skills than others. Some are barely literate; they can read simple messages and write simple messages themselves. Others, can read the daily newspaper, the agricultural bulletin from the extension department and the book of hymns in the church. Most literacy workers use a rule of the thumb and suggest that functional literacy is the ability to read and write as a fourth grader from the formal school system in a particular country or region would read and write. Some literacy workers have tried to define different levels of literacy, for example: capacity to read at the second grade level (first level); capacity to read at the fourth grade level (second level); and capacity to read at the sixth grade level (third level).

Anderson and Neimi, two American adult educators, define literacy levels in the context of American life by differentiating among four types of illiterates:

Complete illiterates: those who have no formal schooling at all.

Functional illiterates: those who have reading skills lower than those of a normal fifth grade child.

Technological illiterates: those who have reading skills lower than those of a normal eighth grade child.

Vocational illiterates: those who have reading skills lower than those of a normal tenth grade child.

Such divisions into levels of literacy are, understandably, arbitrary. The ultimate test is the functionality of the literacy skills learned, though this would mean that we will have to define functionality carefully, concretely, and contextually.

Post-literacy stages. A most important question now arises: After literacy what? Part of the answer, often is: after literacy, a little more literacy. Why? Adult men and women coming out of literacy classes seldom have the capacity to go from their primers and graded books to the real world of printed information in agriculture, health, business, marketing, and the union shop. They need assistance to make the change. It is not surprising that the first post-literacy stage in most countries, therefore, is a teaching stage where literacy skills are put into use in handling printed information produced in the real world of work and life.

But there have to be other stages between the first post-literacy stage and the ultimate goal of creating a society of independent learners and participants in social and political affairs. We do not always know what these stages are or should be. All we know is that:

- (a) those who became literate must retain their literacy;
- (b) those who want to get further education should get it; and
- (c) all others must be provided opportunities and mechanisms for becoming integrated into the society and make economic, social and political contributions to the society in which they live.

It is the main objective of this workshop manual to investigate the three needs listed above.

Post-literacy, adult education, nonformal education and rural development

In the beginning of this chapter, we have talked of the post-literacy stages, and not of one single post-literacy stage. In the first most immediate post-literacy stage, the problem of program planning may be nothing more than providing more literacy; and strengthening the literacy skills by providing reading materials and encouraging new literates to read. However, as we move away from this immediate post-literacy stage, we have to expand our objectives. We have to make a conceptual leap.

As we make this conceptual leap, our programs and curricula will begin to look more and more like programs of adult education, nonformal education and rural development. From the following definitions of these terms, we can see why.

Adult education. "The term 'adult education' denotes the entire body of organized educational processes, whatever the content, level and method, whether formal or otherwise,

whether they prolong or replace initial education in schools, colleges and universities as well as in apprenticeship, whereby persons regarded as adults by the society to which they belong develop their abilities, enrich their knowledge, improve their technical and professional qualifications or turn them in a new direction and bring about changes in their behavior in the twofold perspective of full personal development and participation in balanced and independent social, economic and cultural development." (Article 1, The Recommendations on the Development of Adult Education, Nairobi Conference, 1976.)

Nonformal education. Nonformal education "refers to the motley assortment of organized and semi-organized educational activities operating outside the regular structure and routines of the formal system, aimed at serving a great variety of learning needs of different subgroups in the population, both young and old. Some nonformal programs cater to the same learning needs as the schools and in effect are substitutes for formal schooling." (In the "Introduction" to Education for Rural Development: Case Studies for Planners, edited by Manzoor Ahmed and Philip H. Coombs, Praeger, New York, 1975.)

Rural development. The same source quoted above defines rural development to include all those programs that embrace "all the main dimensions of personal and economic development and of family and community life improvement."

### The use of print and nonprint media

As can be seen from the definitions of post-literacy programs, adult education, nonformal education and rural development included above, there is considerable overlap in their objectives, potential clients and programs. The distinctions among them may often lie only in the eyes of the beholder and in the perspective of the program planner.

An ever more crucial question that must be faced is: Must post-literacy programs be based exclusively on literacy skills? In other words, must post-literacy programs use only print media to be called post-literacy programs?

The answer we suggest is that post-literacy programs must not confine themselves to the print media alone. Indeed, it will be dogmatic and unduly restrictive. But when using nonprint media in post-literacy programs, planners must not make assumptions of illiteracy among their clients. The participant groups should be assumed to be literate; the illiterate should now be considered the "unusual" participant.

A caution. But even as we make assumptions of literacy among our participants during the post-literacy stages, our programs should be so organized that the illiterate is not excluded from the possibility of participation. If we make assumptions of literacy and neglect the possibility of the presence of illiterate participants, we may do great disservice to individuals and communities we seek to serve. We might in fact disfranchise the illiterate.



### Curriculum development

Curriculum, in the dictionary meanings of the term, is a "course of study". Curriculum development, therefore, means the process of designing a course of study according to a set of requirements. To design curricula for the post-literacy stages within the context of a national program in a country, we will have to know what the requirements are. These requirements, on the one hand, will have to project national needs; and, on the other hand, will have to satisfy the social, economic, political and educational aspirations of different clients and constituencies.

The following specific questions will have to be considered:

1. What should be the content of the curricula at the post-literacy stages of the program?
2. Who should be the recipients of those curricula?  
Should we include farmers and workers? Should we accommodate youth and the young school leavers--both boys and girls?  
Should we include people who want further formal education?
3. What should be the general educational approaches to be used? What should be the settings for learning? What should be the main theme: productivity or conscientization?
4. What should be the delivery systems for delivering the curricula to the prospective learners? Should the emphasis be on face-to-face dialogic action or on the use of

technology and distance education? (See H. S. Bhola, Curriculum Development for Functional Literacy and Nonformal Education Programs, 1979.)

### Program development

Curriculum development, as we have indicated, is the development of a course of study; it is the process of developing educational schemes. But all problems in the real world are not educational problems. Programs and projects will have to be designed that link people with economic, and political institutions. People have to be helped to use literacy in improving productivity on their farms; and to find jobs or to get into small businesses or manufacturing for themselves. They have to put literacy to work to get health education and health services and to plan their families; they have to join cooperatives, workers unions and local party cells; they have to become participants and get counted. This will not happen if there are no programs to prepare people for new roles, to provide them the taste of what it means to put literacy to work, to ask and to assert; and unless there are mediating and enabling institutions to assist new literates. To sum, curriculum development will have to be complemented by program development, if post-literacy plans have to succeed.

### Summary

Definitions of terms such as illiteracy, pre-literacy, literacy, and post-literacy have been provided. Post-literacy programs have been put in the context of adult education, nonformal education and, finally, rural development. The processes of curriculum development and project development have been defined as springboard for discussion in the following chapters.

### Things to do or think about

1. Do you have a pre-literacy program in your country? What are its objectives? Are those objectives being successfully achieved? Are pre-literacy programs sensitizing adult men and women to the needs of literacy for effective functioning in the emerging society? Are any of those sensitized adults actually asking for literacy classes to be made available to them?
2. Does your literacy program define different levels of literacy? What are those levels, if any? If reading tests are being given at any level, what are those tests equivalent to in terms of the formal school system?
3. Do planners in your country conceptualize one or more than one post-literacy stages? What are being seen as the essential objectives of post-literacy work in your country? If there are more than one objectives involved, which objectives are seen to have priority over the others?

4. Is there any distinction being made between programs for post-literacy and programs of adult education? What is the distinction? Has it been possible to maintain this distinction in operational terms?
5. Can you name some interesting examples of the use of nonprint media to promote the use of print by new literates?

#### Readings and references

Josef Muller (Ed.), Functional Literacy in the Context of Adult Education (Final Report of the International Symposium organized by the German Foundation for International Development in Cooperation with the International Institute for Adult Literacy Methods and the German Adult Education Association, 15-25 August, 1973 in West Berlin), 1973.

As the title of the report suggests, this document puts literacy work in the context of adult education.

## CHAPTER II

### A CATALOG OF NEEDS IN THE POST-LITERACY STAGES

---

#### Organization of the chapter

This chapter is actually four chapters in one. Four main sections follow an introduction wherein a model of planning post-literacy programs has been presented. The outline is as follows:

A model for planning post-literacy programs

The meanings of development

A systems view of literacy and development

Our clients and the context of our work

Section 1: Programs for literacy retention

Section 2: Post-literacy programs: second chance formal education

Section 3: Systemic integration between literacy and developmental objectives

Section 4: Socialization for an ideal society

---

The post-literacy stages of literacy work and its attendant problems were "discovered" by adult literacy workers. Literacy workers, in as diverse places as India, Thailand, Colombia and Tanzania, found that of those adult men and women who did become literate by attending their literacy classes, not all stayed literate. Many of them

relapsed into illiteracy. The reason for this loss of literacy skills, it was discovered, was the lack of continued use of literacy skills acquired in literacy classes. The skills learned were thus lost through disuse.

The question that came to the minds of literacy workers was: Why didn't these newly literate read? Then, there arose the prior question: Read what? (There also was the "Why" question: Why should adults read? But this question did not always occur to most literacy workers.) Literacy workers discovered that adult men and women who came out of their literacy classes were not able to read the newspapers and the trade books available to the general public. These materials after all had been written to be read by a small class of urbanized and elitized individuals and not by the newly literate, with his minimum of reading skills and his inability to relate to the cosmopolitan world to which most of these reading materials related.

The problem of post-literacy, therefore, was seen by literacy workers to be essentially one of providing--writing and distributing--specialized reading materials for the newly literate men and women. These materials had to be simple in language but had to include adult ideas of direct and immediate use to the farmer, worker and housewife, as they struggled with their daily lives on the farms and fields, in factories and at home.

To sum, until recently the problem of post-literacy was narrowly conceptualized to relate only to the newly literate adult men and women coming out of literacy classes; the problem was defined in terms of retention of literacy skills once acquired; and the solution to the problem was to write specialized reading materials--followup books and rural newspapers--and distribute them through libraries and similar arrangements of some kind.

#### A model for planning post-literacy programs

The 1970s saw a crystallization of some important ideas that have led to a wider definition of the scope of the problem of post-literacy stages; and require a response that is much different programatically from merely writing and distributing materials for the newly literate. This is what has happened:

1. There is a new definition of development around. The measure of this development is man. The new definition of development requires that adult men--and women--liberate themselves from ignorance, oppression, and hopelessness and become active participants in the economic, social and political structures that constitute their societies.
2. There has emerged a new systems view of education that looks at formal, nonformal and informal education as one overall system with the various sub-systems in it interacting with each other.

3. The role of education--and, specifically, of literacy--in development has come center stage.

This has meant the following in terms of the scope of the problem of post-literacy: (a) The constituencies and clients of post-literacy programs have become both more numerous and differentiated; (b) The problems of post-literacy are now not merely of retention, but include, additionally, a second chance for further formal education; integration into the social, economic and political processes and structures of the society; and preparation for citizenship in the ideal society visualized by the national elite; and (c) The solutions are, naturally, not merely educational and those of curriculum development, but include those of program development and the institutionalization of these programs. A model for conceptualizing the needs and scope of program and curriculum development in the post-literacy stages is presented on the next page and should be carefully reviewed.

#### The meaning of development

The concept of development itself has undergone a development of sorts. Development is no longer described in terms only of savings and capital formation, industrialization and import substitution, and development of infrastructures of roads, bridges and telecommunications. Development is today rightly construed as the development of man.



CONSTITUENCIES AND CLIENTS.

I Adults from Literacy Classes

I.1 Rural  
 I.1.1 Men  
 I.1.2 Women  
 I.2 Urban  
 I.2.1 Men  
 I.2.2 Women

II Youth/ School Leavers

2.1 Rural  
 2.1.1 Boys  
 2.1.2 Girls  
 2.2 Urban  
 2.2.1 Boys  
 2.2.2 Girls

III Other Groups & Publics

CATEGORIES OF POST-LITERACY PROGRAMS

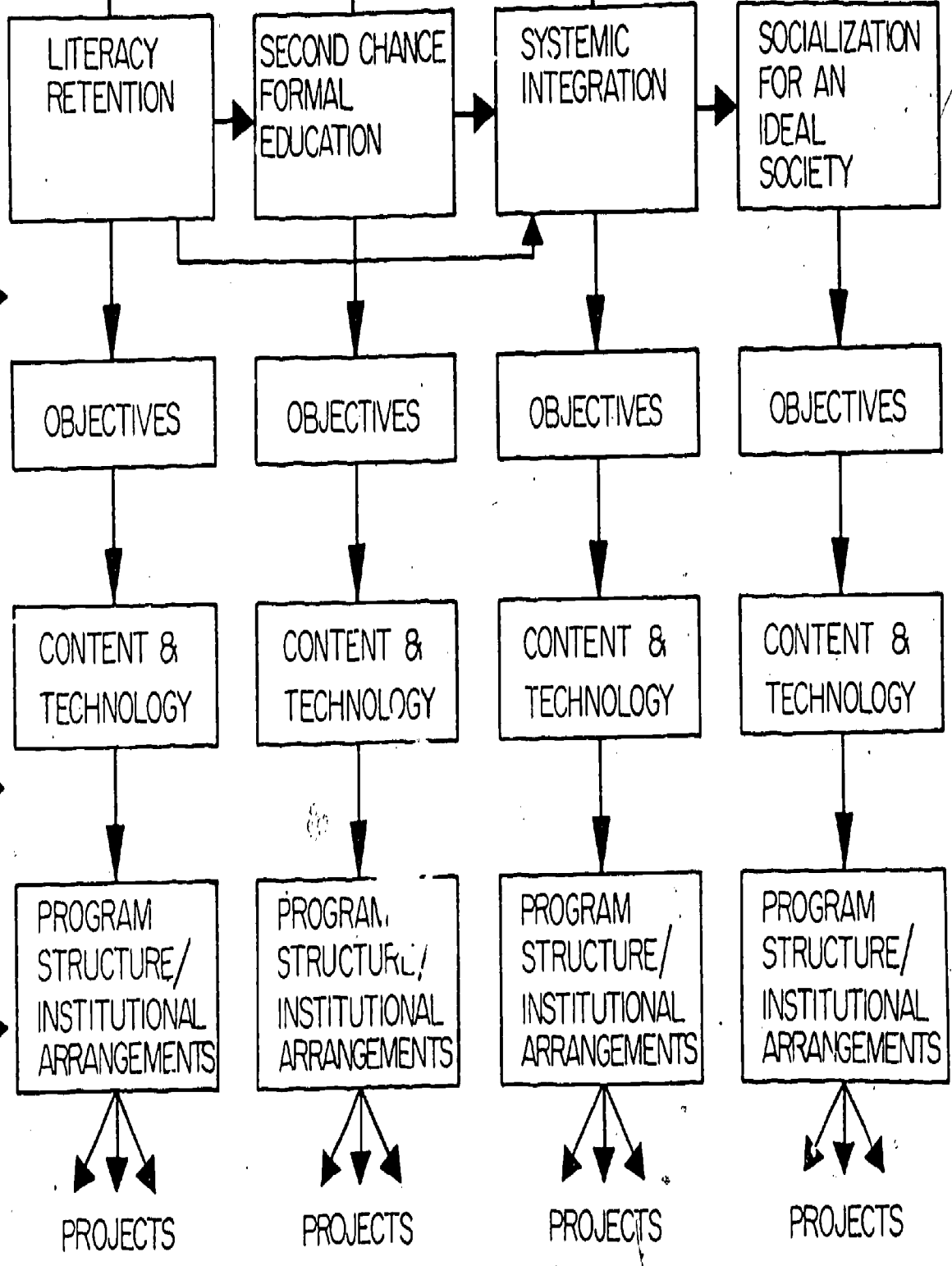

Figure 2.1: A model for conceptualizing the needs and scope of curriculum and program development in the post-literacy stages. (Bhola, 1980).

The following then are seen to be the essential features of development. First and foremost, it is man-centered. Development is seen as the development of man. It means that man is truly franchised and is given the right and the opportunity to achieve growth and a sense of personal worth, to become self-reliant and to participate in the design of his own destiny. This means consciousness-raising and education.

But men cannot live by books alone. Education and participation in decision making alone do not fill stomachs. And in the Third World countries hunger and want are a stark reality. All development in the Third World must, therefore, include more production, with a just distribution of what is produced. It must also involve health care and housing. Basic needs of food, shelter, health and education must be fulfilled. A new material order must be created at the same time that a new political and a new moral order is brought into being.

All this means that new structures must be created and some existing structures must be adapted to new functions-- to serve the disadvantaged and the excluded. It also means that the disadvantaged and the excluded must be educated to participate in these structures and demand that they serve them and be responsive.

### A systems view of literacy and development

In commonsense language, to have a systems view of literacy work means to understand the interdependences and interconnections among and between:

- education and development
- education and changes in social, economic and political structures
- formal, nonformal and informal education
- literacy, adult education and agricultural and health extension, and
- print and nonprint media applications in delivering all of the above.

At one level, the planner of post-literacy programs and curricula must understand that literacy and education alone will not change the lives of people; and that appropriate changes must be brought about in the social, economic and political structures in which adults live. In other words, the rules of the game in the society must be changed. At another level, the planner must understand the linkages between formal, nonformal and informal education, on the one hand, and between post-literacy and agriculture and health extension, on the other. Finally, the post-literacy planner of programs and curricula has to think not only in terms of print but also in terms of the nonprint media--radio, folk media and, where possible, television.

### Our clients and the context of our work

Planners of post-literacy programs must not lose sight of the realities of the world for which they are planning and the differentiated groups of clients they seek to serve. First of all, it is not only the people who came out of the adult literacy classes that must be served. Post-literacy programs and curricula must be planned for the total community of readers whether they came out of the adult literacy classes or out of the elementary schools as school leavers.

Planners of post-literacy programs must pay special attention to women and, what in some countries are called, the weaker sections of the society. Those are the people who have been disadvantaged for so long that they have become "invisible" and are particularly hard to reach. Again, both rural and urban needs must be met. There is justification in the criticism that is sometimes voiced that most literacy workers think of literacy as a purely rural phenomenon. This is not necessarily so. With the increasing urbanization of societies in Asia, Latin America and Africa, we must keep a bi-focal program focus, planning for both urban and rural peoples.

Sociologists have sometimes defined the context of our work as the culture of poverty. And Paulo Freire has talked in his book, Pedagogy of the Oppressed (Herder, New York, 1972) of the culture of silence. Such characterizations may

make some other sociologists uncomfortable. However, there seems to be no problem in accepting the fact that the disadvantaged do often develop their own special world-view, their own strategies of survival and net of mutual expectations between themselves and the outsider. Also, it is possible that their existing patterns of living and their present lack of resources will make it difficult for them even to avail of the new services offered to them. These various considerations must be kept in mind in planning.

Section 1  
Programs for Literacy Retention

---

Organization of the section

Causes of relapse into illiteracy

- Retainable literacy
- Rusted skills and relapse into illiteracy

Who are our potential readers?

Giving our readers reasons to read

- Determining reading needs of adults
- Teaching new reading needs
- Cultivating the reading habit

Books and other reading materials for new readers

The broad band of messages needed by today's citizens

- Reconciling readers' interests and development needs
- Traditional and contemporary themes
- Integrating the scientific and the humanist cultures
- A bifocal vision including the local and the global
- The rural and the urban
- The mass-elite orientations
- Male readers and female readers
- Ecological sensitivities versus consumption orientation
- Greater productivity versus distributive justice
- Information versus identities
- The folk and the formal

Magazines and newspapers for new readers

- Rural newspapers
- Magazines for new readers

Writing needed materials

- Management of special incentives
- Writers' workshops
- Multiplication of resources

## Bringing reading materials to the readers

Selling books to new readers

Libraries--sedentary, mobile, in baskets and boxes

Making books and reading materials psychologically salient and accessible

Using nonprint media to promote print media

Book exhibitions

Book clubs

Institutional approaches to literacy retention

Summary

Things to do or think about

Readings and references

It makes sense that literacy once attained should be retained. The fight against illiteracy will never be won if those made literate, later relapse into illiteracy. And yet this is exactly what has often happened. Why?

### Causes of relapse into illiteracy

There are two causes that have been suggested to explain relapse into illiteracy:

1. The literacy taught to adult learners was too low to begin with and thus was not really retainable.
2. There was nothing available to read after literacy, so that the literacy skills learned died through disuse.

### Retainable literacy

Some literacy workers (and linguists) believe that literacy skills once acquired are for ever retained (even though they may get a little bit rusted through disuse), if these skills are initially learned at a satisfactory level. What they are saying is that those who have relapsed into

illiteracy had not in fact become literate in the first place.

There may be some truth in this assertion. Indeed, some of the definitions of literacy have been naive and some deliberately irresponsible when, under pressures of crash campaigns and the need to succeed, literacy workers have declared as literate anyone who learned to sign his name or came to class, more or less regularly, twice a week for 10 to 12 weeks. Critics suggest that literacy skills have a chance to get consolidated only if they are at least equivalent to the literacy skills of an average fourth grader in the formal school system. Once an adult literate has learned to read at that level, he or she would retain literacy skills for ever.

#### Rusted skills and relapse into illiteracy

The preceding is a consideration that can not be easily dismissed. It suggests that standards for adult literacy be chosen with care. We should not be satisfied with rudimentary, semi-literacy.

But then we know that disuse does lead to rusting of acquired literacy skills. Even when retainable levels of literacy skills have been acquired initially, skills will get somewhat rusted from disuse. When the acquired literacy skills were not satisfactory in the first place, total relapse into illiteracy may result. Thus literacy must be put to use to be retained.



The problems and issues in the area of programming for literacy retention, thus, get defined as follows:

1. To know who our potential readers are;
2. To give our potential readers reasons to read;
3. To have books and other written materials that our readers would be and should be interested in; and
4. To make these materials accessible to our potential readers.

#### Who are our potential readers?

As we have mentioned before the problem of relapse into illiteracy was discovered by literacy workers, but the problem is not unique to out-of-school education. It relates equally well to products of our formal school systems. Millions of children coming out of elementary schools in Africa, Asia and Latin America (who are unable to go to secondary schools and become "school leavers") also relapse into illiteracy. And once again for a combination of two reasons already cited: some had not become fully literate in the first place; and others got their skills rusted for they had nothing to read.

Therefore, it is essential that as we plan our programs of literacy retention in the Third World countries, we do not make the error of conceptualizing the problem merely in terms of newly literate adults coming out of our literacy classes. We absolutely must think in terms of all our potential

reading publics which include our school leavers both from primary and secondary schools. We must pay special attention to the needs of young girls and adult women, two constituencies which have been neglected too often for too long. And we must serve the needs of both the rural and the urban populations at the same time.

#### Giving our readers reasons to read

Since we can not force people to pick up a book and insist on their reading it, all reasons for reading will have to be personal and self-generated. Some of these reasons for reading a book may already be latent among our potential readers while some others may have to be learned, and internalized. This means that we should show our potential readers how books can fulfill many of their personal needs; we should cultivate among them the reading habit; and the society and its various institutions must reinforce among our clients the new behavior of reading to learn.

#### Determining reading needs of adults

Quite a bit of survey research has been done on the subject of reading interests of adults in different parts of the world. Typically, adult educators have gone to adult men and women and have asked them what they will like to read. These are adults who have not seen anything much beyond the primer from which they learned to read, and who do not always realize the possibilities of reading in various

areas. No wonder, the answers have been determined by the questions asked. One thing is quite sure, however. People want to read to fulfill a variety of needs: to kill time, to know of current events, to learn practical skills and to meet practical demands of their daily work, and living, and to meet spiritual demands of their lives. Developmental themes are not the only things they want to read!

Since, we so often misjudge the learning and reading needs of women, it will be useful to report on a survey of reading needs of women in some Kenyan communities done by Dr. Marian A. Halvorson. She found that women do not simply want to learn about child-birth and child-care, and about cooking and nutrition. They want to know also about agriculture and animal husbandry; and crafts and cooperatives; about water development and land erosion; about inflation and unemployment; about alcoholism, widowhood, dowry, and divorce; about justice and morality; about tribalism, citizenship, and travel; about people at home and in other parts of the world; and about death and life after death. This should give us all food for thought.

#### Teaching new reading needs

Adult educators and literacy workers are not merely interested in fulfilling already existing "felt needs" of individuals and communities. They are also interested in teaching new needs such as national integration, brotherhood

of man, balanced diet, improved agriculture, family planning and health, collectivism or Ujamaa, and so on. Potential readers will have reasons to read books about some or all of these topics only if they are rewarded for reading these materials by individuals and institutions in the society. This means, at one level, the creation of a learning environment and, at another level, the creation of political, social and economic structures which require literacy and reward participation in those structures by the newly literate.

#### Cultivating the reading habit

People may have personal, social and economic needs; and they may have information needs for fulfilling their substantive personal, social and economic needs. It does not follow, however, that they will read a book to fulfill those information needs. They may still want to go to a neighbor or a friend, the village chief or an opinion leader; or they may prefer listening to the radio. The reading habit, we now know, is determined by a complex of four variables:

1. the social structure;
2. the quality of the social role;
3. the habit of using information, in general; and
4. the existence of a reading culture.

As we can see from the preceding, establishing the reading habit will be difficult, but it is not impossible. As literacy workers, trying to promote the reading habit, we have to live with the culture and its orientation to reading. The social structure itself must be taken as a given in the immediate present. The other two variables are perhaps more easily manipulable. We must promote the view that reading is not only for the lawyer, the judge, the teacher and the extension worker; that reading is for every one. We must indeed make reading part of the basic productive roles of the farmer, the laborer and the housewife. We must also promote the new orientation that most problems have solutions, if we know where to get the information to invent those solutions. We must make the habit of looking for and using information as natural as breathing, walking and sleeping.

#### Books and other reading materials for new readers

The fact is that in most countries we do not have the books or other reading materials that our potential readers would probably want to read; or what we would want our potential readers to read to serve collective ends. Many Third World adult literacy programs have been unable to pay any attention to post-literacy stages for the sheer lack of resources. They have not been able to produce much by way of followup literature for new literates. (It is necessary to produce special materials for the newly literate and the

school leavers because books in the trade book market are often beyond the intellectual reach of new readers.) Available titles, especially written for new literate adults, seldom deal with much more than growing more wheat, killing field mice, and storing sorghum, etc. That is, when they are available at all.

The broad band of messages needed by today's citizens

In a paper, "Reading Materials for the New Reading Publics: A Policy Brief," written for the International Institute for Adult Literacy Methods, I had suggested that a policy maker engaged in the development of a book production program for new literates must have a vision that accommodates both individual needs and the societal needs; and must take in view both the immediate, the distant, the local and the global. I had suggested that the adult educator, as policy maker in the book production area, must seek to find a balance among the following and along the polarities representing different contents, clients, and interests:

Readers' Interest-----	Developmental Needs
Traditional Heritage-----	Contemporary Issues
Humanist Culture-----	Scientific Culture
Local-----	Global
Rural-----	Urban
Mass Orientation-----	Elitist Orientation
Male-----	Female

Ecological/Conservationist-----Consumption Oriented  
 Productivity Goals-----Distributive Justice  
 Information Dissemination-----Identity Definition  
 Folk Forms-----Modern Forms

Reconciling readers' interests and developmental needs.

Book publication policies must strike a balance between the social and development needs of a community, on the one hand, and readers' interests, on the other. Social and development needs can often be defined by the power and developmental elite of the society. However, readers' interests are not always as easy to determine. In addition to the remarks already made under the section, "Determining reading needs by adults," some further comments will be appropriate.

Various surveys of readers' interests have been developed over the years by adult educators in various settings and contexts. Some of these have been systematic, others quick and impressionistic; some are old, others much more recent; and all of them mutually inconsistent. Agriculture<sup>1</sup> was the foremost expressed interest in one survey, folk and religious literature in another.<sup>2</sup> A

<sup>1</sup> Mushtaq Ahmed, An-Evaluation of Reading Materials for Neo-Literates and a Study of their Reading Needs and Interests. New Delhi: Jamia Millia Islamia, 1958.

<sup>2</sup> Referred to in T. R. Nagappa, "Work-Oriented Literature for Neo-Literates--A Team Operation," Indian Journal of Adult Education, Vol. 32, No. 7, July 1971, Pages 15-16.

Tanzanian<sup>1</sup> sample of new readers' first preference was biographies of community and political leaders; and a group of Nigerian<sup>2</sup> women were most interested in shopping. Ordering of items of interest in different lists has varied. Literature, folk stories, biography, religion, history, philosophy, arts, social sciences, general knowledge, science, family health, child-care, home-making, preparing and serving foods, games and sports, recreation, development, handicrafts, occupational techniques, business, citizenship and Dharma (Man's duty in this world) all have appeared in one survey or another of readers' interests. Answers seem to have often been artifacts of the questions asked. Again, what was expressed interest was not always the actualized interest. A 1962 study conducted by the National Fundamental Education Center (now the Directorate of Adult Education in New Delhi)<sup>3</sup> found that rural subjects desired to read science, literature, religion and agriculture almost equally but actually two-thirds of the reading was in literature and

---

<sup>1</sup>This Tanzanian survey of readers' interests was conducted by the Institute of Adult Education, University of Dar-Es-Salaam with a sample of 800 adults in the four Lake Regions and was briefly reported in Literacy Today, Vol. 2, No. 6, November-December, 1974.

<sup>2</sup>Survey reported in Literacy Today, Vol. 2, No. 5, September-October, 1974.

<sup>3</sup>Quoted in H. S. Bhola, "Books for the New Reading Public," Lekhak (Quarterly Newsletter of the School of Social Writing, Mass Communication and Training Department, Literacy House, Lucknow.), Vol. IV, No. 2, July-September, 1967.



folk literature, one-fourth in religion and only one-tenth in science.

A reasonable generalization that can be made is that adult readers do want to read developmental material and material that will teach them economic skills. But they do also want to read more generally in religion, history, technology, and politics. They also want to read for pleasure. Any policy designer concerned with the formulation of publication policies for books for adults must reconcile these two pulls between needs as defined by development elite and interests of readers for whom those books will be written.

Traditional and contemporary themes. Publication policies for reading materials for the new readers must also keep a balance between traditional themes and contemporary themes. While the new readers are fed on themes of developmental plans, new social aspirations and economic possibilities, they must also be put in touch with their old heritage. This could be done by re-telling the great epics, classics and folk stories of the culture in simpler language and by otherwise treating traditional themes of history and culture in the literature for new literates. Both India and Brazil's M6bral have done excellent work in editing classics from the "public domain" and adapting other popular works for their new readers.

Integrating the scientific and the humanist cultures.

C. P. Snow<sup>1</sup> in his book published in 1959 talked of the Western intellectuals having come to be divided into two cultures--the literary (or the humanist) and the scientific. He observed that there was little common between these two cultures in terms of their intellectual, moral and psychological climates; and, regretfully, they had almost ceased to communicate with each other. The problem is not merely Western; and the division between the scientific and the literary cultures in developing countries is even more acute. This division between the two cultures is reflected also in the adult education sector. Most of those now working in adult education have typically come from the literary culture. The scientists, doctors, engineers and others trained in the scientific culture generally have no interest and no say in the nation's adult education policies. The result is that policy makers neglect scientific and technological realities in most aspects of adult education. Even though most people in most places in the world are enveloped in technology, yet technology and science are not reflected in the publication programs of books for the new readers.

Indeed, the separation of the humanist and the scientific cultures in the Third World could be tragic. We

---

<sup>1</sup>C. P. Snow, The Two Cultures and the Scientific Revolution. Cambridge (England): University Press, 1959.

would not, perhaps, suggest the banishment of all that is "magical" from the lives of people in the Third World but the scientific must be now introduced. The scientific and technological challenge in the developing countries must in fact be met at two levels: developing countries not only need to produce scientific manpower, they must also create scientific-technological cultures where farmers and workers can learn to "experiment" at home, in the field, and in the work-place.

A bifocal vision including the local and the global. While fulfilling specific and local needs of communities, books must open up new horizons for their adult readers. They must socialize them for a world citizenship. Books must make adult readers meet their neighbors, see them at work, at play and at home to understand the common humanity of us all. They must help us understand "culture as play" and to know that different cultures play different cultural games. They must enable us to get beyond the abusive and the frivolous stereotypes of each other. We must all learn that the pride of families, and the power of nations will not be furthered by out-procreating other families and other nations; and that the future of the planet might not be safely left in the hands of autonomous nation-states, including our own.<sup>1</sup>

---

<sup>1</sup>Willis W. Harman quoted in Paul Dickson, Think Tanks. New York, N.Y.: Atheneum, 1971, pp. 337-388.

At an intermediate level between the global and the local, publication policies must reflect the national ethnic and cultural richness. Books must be written that talk of special minorities and communities within a society; and of their feasts and festivals without promoting the ethnocentricity of the majority that might patronizingly study its own tribes and minorities.

At the same time, reading materials must deal with the specific, local, social and identity needs of the groups they serve. After all it is possible today to print books in editions of a hundred to a million or more. There would be the need, and there should be a place in policies for book production to produce books in limited editions to fulfill specific needs. Specificity of reading needs, in itself, can be of two kinds: (a) situational specificity, and (b) reference group specificity. A group of readers, that is, may be specific to a place. They may be all living around Lake Victoria in East Africa and may have a common need arising from that situation. At other times, the group of readers may be spread all over a region or all over the world but may still have specific interests that are not more generally shared.

The rural and the urban. Most underdeveloped countries are basically agrarian societies. Most of their people live in rural areas--in villages, in the bush or on the campo. But policy makers engaged in the design of plans for

the production of reading materials must not neglect the urban demography of their countries. With hardly an exception, all developing countries have urban centers and those urban centers, inevitably, have their slums. The urban proletariat, those employed in factories and those unemployed and on the streets, must also be given books to read. Indeed, the urban environment may already have developed among urban adults, needs and compulsions to read which must be served.

The mass-elite orientations. In designing book production policies for the new readers, an adult educator needs to watch on both sides of the mass-elite issue. A policy maker should neither impose on the masses his elitist values about content, treatment and form, nor attribute vulgarity to the masses and provide them with simple-minded and lowbrow reading.

Male readers and female readers. The recent flowering of women's liberation movements, in some form or the other all over the world, has brought home to us the cruel facts of how women have been abused at home and in the field and denied the right to envision, to govern, to decide. The area of production of reading materials has also been a man's world because literacy programs had often been organized for men rather than for women. Special efforts should be made by policy makers to serve the reading needs and interests of women both in the urban and rural areas, so

terribly neglected thus far. Also women need not any more be seen merely as housewives and homemakers, with interests only in child-care and family food. Now that women have been discovered at last, they should be seen as more than one-dimensional, as whole persons with needs to learn about power and status and government and with needs to be entertained by what they read.

Ecological sensitivities versus consumption orientations. Some social commentators have argued that the hidden curriculum of formal education has been more effective than its manifest curriculum. They assert that even when schooling failed to teach reading and writing, it yet succeeded admirably in coopting learners to the industrial order and in teaching them grossly exaggerated consumption behaviors. Products of schooling have thus, watched the destruction of their physical environment--killing of birds and animals, cutting down of trees and poisoning of their air and waters--as they have blissfully gone about buying and consuming more and more material goods. Adult educators in the Third World must avoid this from happening to their communities. The reading materials while inspiring adult learners to produce more to fight dire hunger, and encouraging them to use technology to make their lives more humane, must not dull their ecological sensitivities. Books for the new readers must teach that progress can go together with conservationism and environmentalism.

Greater productivity versus distributive justice.

Again, while adult educators and functional literacy workers in the Third World have emphasized greater productivity in the field and in the workshop, they have not always addressed themselves with the necessary zeal to questions of distributive justice. Development does not mean merely more production, but also it means changes in the political, social and economic institutions of a society to achieve a more just distribution of the wealth produced. Book production policies must respond to both these needs of greater national productivity and of distributive justice.

Information versus identifies. Development of individuals, communities and nations is not merely a question of dissemination and utilization of more and more development information and communications. Deep transformations of individual and national identities are involved. New tools and modes of production change a man's relationship with other men and with the world in general. This puts individuals through identity crises. At the community and national levels, again, redefinitions of images and identities become necessary. Books for the new literates, who would most often also be subject to development processes, must help them through these changes of identity. Writing such books should be a challenge to the very best in any nation.

The folk and the formal. Finally, publication plans of adult educators have often emphasized the prose narrative. This inspite of the fact that the new adult readers in the Third World are often closer to the poetic tradition than to the prose narrative and often have rich folk forms in which new meanings and messages could be put. Cultures that have poetic traditions also produce poets of their own. In India it was possible to recruit dozens of poets for the writers' workshops for writing books in poetry for new literates. It should not be difficult to find poets in Iran or China or Bolivia or among the Yoruba in Africa who are known to have an intense interest in poetry and the verbal arts. While we are aware of the fact that prose has sometimes been read more than poetry and poetry more than drama, poetry and drama as forms of expression should not be neglected.

Magazines and newspapers for new readers

The idea is not merely to make new literates readers of books and, therefore, consumers of information available in cold print. We must be able to establish a more dynamic relationship between the new literate and information in print. For instance, the new literate must himself or herself become an information producer (a codifier of the reality that surrounds the new literate). It also must become clear to new readers that information is in flux; it is always in the making; and quite often it is stale and out



of date even before it can be put into the form of a book.

Rural newspapers. The best tool for establishing a dynamic relationship between new readers and information is the rural newspaper. It can be used to invite new literates living in the remote rural areas to produce their own information, of interest to them; and share it among those who do not have that information. In producing a rural newspaper, the process of codification of reality can become objective for those who produce the newspaper as well as for the immediate consumers of this information with whose lives it deals with. It will thus teach new readers how to read--critically--information codified by outside their reality. It will also show the ephemeral nature of some information and point up how some information may be more lasting than some other.

Aims of the rural press are, typically, defined as follows:

- (1) to provide reading material for new literates;
- (2) to ensure the continuing education of the rural masses; to give them practical advice on production and civic rights and responsibilities;
- (3) to give the masses information about events concerning their environment, their region, their nation and the outside world at regular intervals;
- (4) to ensure a "dialogue" between the leaders and the rural masses;

- (5) to help ensure the participation of the rural masses in the economic, social and cultural development of the nation;
- (6) to proceed to set up a local, decentralized press and to show the rural masses how to express themselves in the press;
- (7) to introduce the rural masses to the reading of newspapers.<sup>1</sup>

The rural press, fortunately, is not merely a hope, there are already rural newspapers being produced and distributed in places all around the world. A document prepared by the UNESCO Secretariat for the International Symposium for Literacy, Persepolis, Iran, (September 3-8, 1975), had this to say about experience with the rural press:

"In spite of the many problems caused by the lack of financial resources, the lack of printing facilities, of paper, of distribution systems, more than 30 countries in these last years have been able to produce and distribute periodicals and newspapers especially designed for new literates, often in local languages. Among the most lively: Kibaru in Mali, Ruz-Nau in Iran, Bekham Bidan in Afghanistan, Sengo in the Republic of Congo, Game-Su in Togo, Elimu-Haina-Mwiso in Tanzania, Saabon Ra'avili in Niger, News for All in Jamaica, New Day in Liberia, Ujala in Uttar Pradesh, India. The Mobral publishes, fortnightly, two newspapers: one "Journal do Mobral" in two million copies addressed to the learners attending literacy courses, and another one: "Integracao" for the neo-literates. It should be added that regular newspapers in Tanzania, Zambia, Tunisia, Thailand and Venezuela and other countries, devote a part of their space to articles for new readers."

---

<sup>1</sup>Hifzi Topuz, "Creation of a Rural Press for the Newly-Literate," Literacy Work, Vol. I, No. 4 (January, 1972), Pages 87-88.

As policy formulators, we should, however, consider some problems inherent in the establishment of newspapers for rural readers. First and foremost are the problems of distribution of the newspaper, with the observe of this same problem being the problem of collecting local and regional news. In localities where the infrastructure of roads, trains or buses does not exist and postal services are infrequent or non-existent, the only choice available to the newspaper publisher is to develop his own infrastructure. That can be very expensive even in projects with scores of landrovers and jeeps shuttling around in the bush or in and around the villages. This author's first-hand knowledge of the problems of distribution of Literacy House's Ujala in Utter Pradesh, India and of Habari Ya Busega in the Lake Regions of Tanzania was indeed sobering. Equally sobering was the failure to collect local area news with which the new literates could identify.

Some adult educators and functional literacy workers want the rural newspaper to become the community's own newspaper. They wish that the community itself would take the responsibility of collecting news, editing, editorializing, composing, printing and distributing their own newspaper or at least a news-sheet. The idea sounds too good to be contested. It sounds almost romantic--a community engaged in creating, producing, disseminating information and news about themselves, learning, relating, showing concerns,

solving problems, growing, acquiring conscientization, influencing life in the community and the nation. One must, however, be wary of getting into plans for a rural newspaper without first making a dispassionate analysis of infrastructure, inputs, processes, outputs, and consequences.

#### Magazines for new readers

Magazines for new readers offer a good compromise between the book and the rural newspaper. The magazine format allows more time for collecting local information, writing news features and stories and for producing and for distributing the magazine once it is ready. Like the newspaper it can reflect the realities surrounding its potential readers and yet the magazine need not be distant and impersonal as a book.

#### Writing needed materials

It is not within the scope of this workshop manual to go into the details of how to write materials for new literates. Suffice here to say that writing books, magazines and newspapers for new readers requires special skills and special incentives.

Typically, the strategies used have been:

1. Management of special incentives

Special incentives have been created both for writers and publishers of materials for new literates by awarding prizes to writers and publishers; and by buying copies of

books in bulk for distribution among libraries and community centers.

## 2. Writers' workshops

Special workshops have been held where those interested in writing for new literates have been given special training and orientation in writing for new readers; and have been provided opportunities to actually produce manuscripts for publication under the guidance of workshop teams.

## 3. Multiplication of resources

There have been attempts to multiply scarce resources available to Third World countries through useful collaboration. This has meant that governments from a particular region with shared cultural heritage and language have shared each others resources in writing materials for new literates. A useful recent example is the "The Asian Copublication Programme" under which many Asian countries have gotten together to write series such as Folktales from Asia and Festivals from Asia and then made manuscripts available to each other for translation and minor adaptation.

## Bringing reading materials to the readers

Finally, the problem is to bring the reader and the reading material together. In other words, the reading material must be made accessible to the readers. This question of accessibility can be seen to have two aspects: (a) psychological accessibility; and (b) physical

accessibility. Various aspects of accessibility are discussed below.

#### Selling book to new readers

It is quite understandable why it has been impossible to sell book to new literates in the Third World. For those living in subsistence economies and close to poverty levels, books compete with their more immediate needs for food, clothing and shelter. Even in rich countries of the world, books have not entered all homes. But there are hopeful signs. The Japanese have tried "one-book-in-every-home" movement with some success. In Brazil, MOBREAL has been able to sell books to new readers at factory gates. And even in Tanzania some new literates claim to buy their newspapers daily and to have bought many books. One of the new literates interviewed by Yusuf O. Kassam for his book, Illiterate No More, claimed to have bought some thirty books.

Yet, it is not the time to start thinking of marketing strategies for selling books to the poor.

#### Libraries--sedentry, mobile, in baskets and boxes

The universal solution to the problem of taking books to new readers has been the library. But libraries are no more visualized as large palaces where high ceilings overawe those who enter; and where visitors walk through long marble corridors to get lost in miles and miles of guarded bookshelves. The new concept of libraries involves unpretentiousness,

openness, functionality and mobility. This means that libraries can be small; no more than a 100 books in a tin trunk or even a basket, carried to a farming community or a nomadic camp, on a bicycle or a camel's back.

Interesting experiments with libraries for new readers have been tried in India, Pakistan and Tanzania, to name only a few countries. Pakistan's experience with farm libraries is interesting, under which 15,000 farmers have been assisted in developing their own individual collections of materials on farming.

Making book and reading materials psychologically salient and accessible

A book may be taken to the reader's doorstep and still not be accepted; and, if imposed, still not read. It is important that the book must become salient in the lives of the common folk and must become psychologically accessible to them.

Using nonprint media to promote print media. Excellent use can be made of nonprint media to promote the print media of books, magazines and newspapers among new readers. It is not as paradoxical as it might seem to some at first sight. Both print and nonprint media have the same objective: to carry to citizens information that they might find educational, elevating, or entertaining. The essential purpose is to make people good users of information and to help them acquire the habit of using information to solve problems.

We also know now that media are not really in competition, but one medium actually promote the use of another. Numerous examples have now become available where an excellent use has been made of the electronic mass media to make books known and to promote their use by those comprising the new reading public. In Austria, a program called Lies Mit (Read Along) reaches some two million households in this country of some seven and a half million and invites them to read. In Brazil, the program Ler e Viver (To Read is to Live) similarly tries to get people interested in reading by programs and spot announcements on radio and TV.

In his book, Roads to Reading, Ralph C. Staiger, talks of the Tanzanian example in these words:

"In the United Republic of Tanzania, radio has been used to maintain the reading impetus generated by the government's mass literacy campaigns.

"More than 6,000 free radio sets have been distributed for the use of listening groups developed from successful literacy programmes. The pattern of programmes which are designed to stimulate reading is as follows: usually a topic is discussed by a specialist and, toward the end of the programme, mention is made of publications which could be used to obtain more information about the subject. Page numbers and other specific directions are given.

"Related discussion topics, in addition to the motivational programmes mentioned above, are: continuing



education by using the library, book-borrowing rules, how to spend leisure time, how to use books for group discussion, how to use newspapers, the library and the teacher, the rural library service, and what should be read and what there is to be read.

"After each topic has been discussed on the radio, a discussion question for the listening group is announced. An example of one of these questions is: What do we gain through reading books, newspapers or other reading materials?"

"In an evaluation of the radio education motivation and functional series, it was found that 69 per cent of the respondents in a representative sample indicated that they read more books and newspapers as a result of the programme. It is important to note that these reading materials were obtained from many resources, including, of course, the rural libraries, but also from teachers and supervisors, from neighbours and friends, school libraries, co-operative societies and political party offices. In addition, some readers bought books as they were available." (Quoted from Ralph C. Staiger, Roads to Reading. Paris: UNESCO, 1979.)

Book exhibitions. Book exhibitions and book clubs have also played an important part in taking the book to the potential reader. Small but attractive exhibitions of books and reading materials can be taken round in cities and to the countryside. Many people in this world have not really seen books, at least not lots of books on display in

one place, all dealing with subjects with which they as individuals have had something to do. Such exhibitions can work wonders. Sometimes, these exhibitions can be made into big events and some selected authors of books can go along with the exhibitions.

Book clubs. Many different activities can be subsumed under the name of book clubs. Some of the book clubs can be used for supervised reading where readers can get help in understanding materials that they may not be able to understand if left to themselves.

Some book clubs may be used to discuss books that participants have read or are likely to read. Even though reading is a solitary activity, people often have the desire to talk about what they have read and book clubs can play an important part in satisfying this urge to talk about one's reading and to discuss the ideas of an author.

Book clubs can also be used for another important activity--to teach critical reading. Such programs may have to be supervised in the beginning by well-trained monitors. These monitors should be trained to be able to state the basic thesis of a book; summarize the main argument; assist participants to evaluate the truthfulness and meaningfulness of the message in terms of their life experiences; and make an analysis of class origins, political leanings and creative interests of the author.

Finally, book clubs can be used to invite readers to be writers themselves. Readers may be invited to collect local folk tales and local history; may be asked to interview older people in the community; or to write original fictional and nonfictional materials.

#### Institutional approaches to literacy retention

Whatever needs to be done systematically and with some continuity, needs a system. This means that literacy workers and adult educators must use institutional approaches to promoting book production, book distribution, the reading habit and the love of books. Some of the institutions already existing in different parts of the world should give ideas to literacy workers elsewhere; for example: National Book Development Council of Singapore; Austrian Bookclub for Children; National Book League of London; Children's Book Council, New York; and Book-Lovers' Association of the Union of Soviet Socialist Republics.

#### Summary

The causes of relapse into illiteracy have been defined as being (i) the insufficiency of the initial literacy skills acquired; and (ii) the lack of use of the skills acquired. A solution to the problem of relapse (or of a rusting of literacy skills) is seen to consist in four parts: identify potential readers; give potential readers, good reasons to read; produce appropriate reading materials for

new readers to read; and make reading materials accessible to potential readers. Various aspects of this four part solution are discussed in detail from the point of view of a program planner and policy maker.

Things to do or think about

1. Do you think that the level of literacy provided to adults in your literacy program is of a sufficiently high level that will make relapse into illiteracy unlikely to occur? Similarly, do you think that schools in your area are turning out youth who are fully literate or do these schools leave something to be desired in terms of the literacy of their school leavers?
2. How do you identify adults and youth who have relapsed or are likely to relapse into illiteracy? What are the typical conditions surrounding an adult who is likely to relapse into illiteracy? What kinds of youth relapse into illiteracy? Do girls and women present any special or additional problems?
3. How long does it take for a newly literate adult or a young school leaver to relapse into illiteracy?
4. Are all your post-literacy programs in the area of literacy retention preventive or do you do something about those who you know have relapsed into illiteracy?
5. In terms of the "broad band of messages" that we have suggested are needed by adults and youth, living in today's fast changing and challenging world, how does your program

measure up in regard to comprehensiveness and choice of priorities?

6. Is the total publications program of the government in public information, agriculture, health, cooperatives, etc., responding to the new reading publics by producing materials at controlled levels of readability so that it could be easily read by new literates? Is the national press serving the special needs of the new literate?

7. What has been the relationship in your country between literacy programs and media programs such as radio? What role is radio playing to promote literacy retention? What more can it do?

8. Do you think there is scope for starting national magazines; one for new literate adults; another for the youth of the country? What kinds of people and what kinds of needs should these magazines serve?

9. Is it possible to do any copublication with publishers and/or governments of other neighboring countries? What are your first thoughts about it?

10. To mount a publication program of the size that the country really needs, does the country have writers, the applied research base, printing capacity, paper and distribution infrastructure needed for the job?

11. What is the status of a library program in your country? What are some innovative strategies developed in the country that literacy workers elsewhere might find worth emulating?

12. Is there scope for establishing book clubs in this country? What should be the nature, objectives, and procedures for such book clubs?

#### Readings and references

1. Ronald Barker and Robert Escarpit, The Book Hunger. Paris: UNESCO, 1973.

The book explores the causes of book hunger in developing countries and examines some possible solutions. Book production, distribution of books among readers, copyright laws and reading habits of emerging new reading public are discussed.

2. Stanley A. Barnett and Roland R. Piggford, Manual on Book and Library Activities in Developing Countries. Washington, D.C.: Agency for International Development, 1969.

The manual presents a compendium of ideas, techniques and procedures regarding book development and book distribution (including library activities) that have been developed and tested in developing countries.

3. Robert de T. Lawrence, Rural Mimeo Newspapers (Guide to the Production of Low-Cost Papers in Development Countries). Paris: UNESCO, 1966.

Based on his experience in Liberia, the author addresses the nonprofessionals on how to develop rural newspapers in rural settings of the Third World countries.

4. Ralph C. Staiger, Roads to Reading. Paris: UNESCO, 1979.

The basic objective of this book is to promote the reading habit among children and adults. It provides helpful ideas and guidance for teachers, administrators and book

professionals dedicated to devising and planning large-scale reading promotion campaigns.

Section 2

Post-Literacy Programs:  
Second Chance Formal Education

---

Organization of the section

The problem and the background of the problem

The point of view of adults

What needs to be done?

Options in program design

The problems of equivalence and relevance  
Systems for delivering second chance education

The ultimate goal

Some experiences

No-school schools

How the no-school school system is supposed to work  
An evaluation of the project impact

Open universities

Philosophy of the open university  
Organization and management  
Programs  
Critique

Parallel systems of formal education

Summary

Things to do or think about

References and readings

---

For many adults, literacy is not its own reward. Their ability to read is not an opportunity to read to learn and



thereby to improve their daily lives; it is a second chance for formal education which was not available to them when they were young, or which they failed to avail of for some reason. After they have got their literacy certificates, they want to get their elementary school certificates and, perhaps, their secondary school certificates, and then find jobs with the government or in some modern sector of the economy.

### The problem and the background of the problem

By most literacy workers, in most parts of the Third World, the preceding is seen as a problematic situation. Why? Here are some background comments by way of an explanation.

Literacy workers wish that newly literate adults will use their newly acquired literacy skills to improve their present lives, not to escape from them. That is, they wish new literate adults to use their literacy skills to improve their productivity in the fields or in their places of work; to learn about health and nutrition; and to become participants in such structures as the cooperative and the village council. They do not like to see their literacy work to contribute to their escape to the town, looking for jobs that do not even exist.

Literacy workers do not always want to encourage new literates to ask for further "certified" education, either. That is, they do not want to encourage new literate adults to pursue second chance formal education at the elementary or

secondary levels. This, again, for the same reasons. The new literate adult or a young school leaver who wants second chance formal education has his heart set on job in the city. The sense of frustration of literacy workers is further heightened because they do not have the resources to provide a satisfactory system of second chance education for all those who want it.

Yet, as literacy workers, we can not say "no" to these aspirations for ever. The social demand is after all one aspect of the peoples' will. We can not neglect social demands for second chance formal education simply because it thwarts our well-laid plans for new literates staying home and using literacy skills in their native social and economic surroundings. There are also ideological reasons. Second chance education is a significant way of opening up the educational system and making education available to those who, for political, social or some other structural reasons, were for decades bypassed by the system.

Finally, there is the consideration that mere literacy is not always enough for the capacitation of adults to carry the heavy burdens of citizenship and trained manpower that we expect them to carry. It is the essential minimum, but a minima nonetheless.

#### The point of view of adults

The point of view of new literate adults who want more education (rather more "certified" education), with the hope

of escaping from present conditions in the village, is easily understandable. They have direct personal experience of drudgery and want in their present situation. They have seen or heard of what the town offers; and how important a certificate is to get a job in the town and partake of what it offers. The failures of many who went to town and were brutalized and defeated are easily forgotten in the favor of even one who made it. The desire to go is overwhelming.

What needs to be done?

What needs to be done is not easy to state. Some of what must be done is actually beyond the power of literacy workers. That is so because political and structural solutions are required which are beyond the capacities of educators. Again, some of what needs to be done is long-term; while some, fortunately, can be handled more immediately, within the settings of our daily work.

One aspect of the task is to break the magic and mystification of a "certificate" that makes people go to towns in the hope of redeeming those certificates in the form of salaried jobs. This is easier said than done. Our societies will have to establish new rules if the game wherein knowing is more important than having a certificate. But more importantly, rural incomes will have to be increased so that they are clearly more attractive than the salaries paid in towns to peons and messengers in offices, and to manual and

domestic workers. In addition, the social and cultural amenities available in the villages will have to be drastically improved for the lure of the city to be broken. These remedies, as we have indicated above, are for the political decision makers to provide; they must make decisions to allocate more resources to rural areas; and they must change planning priorities to improve the lives of rural people.

In the meantime, the only recourse that literacy workers have is to work with individuals in communities and provide them effective counseling and guidance. They must present to them the total balance sheet that shows the material, social and psychic costs and benefits involved in moving to the city. If an individual should still want to pursue second chance education and, ultimately, to go to town he should, then, be helped to do so; and he should be suitably prepared for the encounter with the city.

#### Options in program design

There are two basic challenges in providing second chance formal education to newly literate adults and to school leavers:

1. Designing curricula for adult learners in elementary or secondary education programs which are relevant to the needs and interests of these special learners and which are equivalent to the curricula in use in the mainstream of

elementary and secondary education.

2. Developing a system for delivery of this second chance education to adults enrolled in the programs.

The problems of equivalence and relevance

Adults or young adults who want to avail of a second chance to receive their elementary or secondary education should not be asked to receive the curriculum offered to children in elementary or secondary schools. It will be patently absurd to teach them from the books and instructional materials used in schools for young children; or even to use the teaching methods that are typically used within schools for young children. We must offer to adults and youth relevant subject matter of interest to them, and adding up to a curriculum with which they can relate in their existing conditions of life.

But while this material has to be relevant to the needs and interests of adults, it must also be equivalent to the level and scope of the curriculum for elementary education or secondary education being offered in schools. In other words, the adults and youth now being offered a second chance elementary education must be taught the basic vocabulary, the concepts, the numeracy skills, and the basic information about health, food and citizenship that is offered to children in schools. The difference in the case of adults and youth will be that they will learn these skills

concepts in the context of their particular life-stage and rooted in their life experiences.

#### Systems for delivering second chance education

While adults and youth in developing societies may want a second chance elementary or secondary education, they do not want to go to school. Almost without exception, they want a second chance education as part-time or own-time students. They may be ready to attend classes of some kind as part-time students in the evenings or on weekends. More frequently, they want to be own-time students, that is, they want to learn when it suits them--in their fields, during breaks in their work at the factory, while commuting back home on the train from work, late at night before going to sleep, or early in the morning, or on Sundays and other holidays.

This means that the school should go to the students in their homes and in their fields and factories, and wait until they are ready! This means that the teacher and his teaching should be packaged for delivery by mail or through broadcast by radio or TV. It should come as no wonder that most programs of second chance education--at whatever level--use some form of instructional technology. They are partially or fully programmed and packaged to be sent out in the form of a correspondence course or over the radio, with various combinations of print, radio and personal contact with

monitors and teachers. (See the section, "Some Experiences," below.)

### The ultimate goal

In most parts of the Third World, illiteracy still looms large on the horizon. Eradication of illiteracy is, therefore, the first task. To those who are aware of the reality of scarce resources in education, and in adult education in particular, demands for second chance elementary or secondary education by a group of people might seem unreasonable.

But we must keep things in perspective. Second chance elementary or secondary education might look like an unnecessary burden in the short-run, but it can not, and should not be avoided in the long run. Mere literacy is not enough for the kind of manpower needed for constructing progressive and participatory societies. To create a rural and worker intelligensia, we will need perhaps to make a high school level of education universal in the long run. We may have to do even better than that.

### Some experiences

Experiences of Third World countries with second chance formal education have been more widespread than might seem at first sight. Indeed, for a long time, adult education was confused (and in many countries it still is) with formal education of adults. Continuing education

programs, which in reality are programs of elementary education for adults, can be found in countries as diverse as Bolivia, Brazil, Colombia, Zambia, and India. In India especially, a "private" track for high school and university level liberal arts education has existed for over forty years. The extra mural departments in many of the universities in the British colonies were also a mechanism for second chance higher education.

Technology has changed programs of second chance education for adults in most important ways. The two aspects of technology (the instructional technology and the engineering technology) have made it possible for educators to package instruction in such a way that a "master teacher" is possible to send to all the learners within a system. This would have been impossible without technology. Now with packaged instruction, even a para professional teacher can do a good enough job of delivering instruction. Technology has also liberated education from the limitations of time and space. Instruction can now be delivered to learners who would otherwise be inaccessible; and at times convenient to them.

Radio schools, for example, have served important educational needs of adults (and children) who otherwise would not have attended any school whatsoever. The Colombian Sutatenza School of the Air started since 1976 has offered the rural population a full basic education program divided into four courses: elementary, numeracy and communication,



welfare and economics, and our community. (UNESCO, Adult Education and Information Notes, No. 2/1976, page 5). The radio schools of the Tarahumara, Mexico follow the official curriculum more strictly and use "auxiliary teachers." (Sylvia Schmelkes de Sotelo, The Radio Schools of the Tarahumara, Mexico: an Evaluation. Washington, D.C.: The Academy for Educational Development, 1973.)

Another fruit of educational technology has been the correspondence education, or distance education, as it is sometimes called. Correspondence courses have been designed and made available for elementary and high school education, at the university level, and for specialized groups such as teachers-in-service, engineers, electricians and accountants. Fortunately, experiences with correspondence education are now available to many countries in Asia, Africa, and Latin America; and one does not have to go far to get first-hand experience with correspondence education.

The full culmination of the use of technology to deliver second chance formal education can be found in the two cases reported below.

#### No-school schools

The Southeast Asian Ministers of Education Organization (SEAMEO) in 1968 approved the establishment of a Regional Center for Educational Innovation and Technology (INNOTECH) to develop, test and promote educational innovations that will help solve the special educational problems of countries

in the Southeast Asian region.<sup>1</sup>

Project IMPACT (an acronym for Instructional Management by Parents, Community and Teachers) is an elementary education system which has been implemented on an experimental basis in nine schools in the Philippines for some five years beginning in 1972.

The INNOTECH planners, of course, view Project IMPACT as a cost-effective way of providing mass elementary education to school-age children. However, the Project IMPACT offers designers of post-literacy programs significant ideas and important possibilities in their plans to provide second chance elementary education to adults and youth who could not be reached by the formal education system.

How the no-school school system is supposed to work.  
We include in the Appendices a fictional account of a visit by a reporter to a fictitious community named Sealand where the no-school school system is supposed to have become fully functional. This fictional report was distributed by INNOTECH to enable people to understand what the system would be like if it succeeds. The report is so interesting and informative that it deserves to be read in full. (See Appendices.)

---

<sup>1</sup>INNOTECH Newsletter (SEAMEO Regional Center for Education Innovation and Technology), Vol. I, No. 8, May 1973.

An evaluation of project IMPACT. An evaluation report<sup>1</sup> on the Project IMPACT (by no means fictional, but based on hard data) has shown that Project IMPACT has been able to reduce the cost of elementary education per child by up to 50% without any reduction in the educational attainment of pupils.

With the use of IMPACT technology, there is a potential for greatly improving the quality of elementary education by using the resource savings to provide urgently needed instructional materials to existing schools, to improve teacher salaries, and to upgrade existing school buildings and facilities. The IMPACT technology need not lead to teacher unemployment and may perhaps be the only chance for providing universal elementary education in the Philippines.

Such a system may also be the only chance for a second chance elementary education for adults and youth in most Third World countries and deserves the attention of planners of programs and curricula in the post-literacy stages.

#### Open universities

Another fruit of technology in second chance education has been the idea of open universities. Most of our readers will perhaps be already familiar with the concept. Only a

---

<sup>1</sup>J. C. McMaster, Cost-Effectiveness Analysis of Project IMPACT for the Philippines (A Report to the Australian Development Assistance Bureau for the South East Asia Ministers of Education Organization Regional INNOTECH Center, Manila), August 1978.

very brief description of the idea is, therefore, being offered below. The description is based on the British Open University which has inspired similar open universities in many other parts of the world.

Britain's Open University, set up by a Royal Charter in July, 1969, provides an innovative approach to formal higher education for adults. Openness of the university lies in its admission policies that demand no formal entrance requirements; study at one's own pace and place; and multi-media instructional methodology that caters to the needs of a variety of people. It has its own academic advisory committee but traditional universities are also consulted in planning and evaluation of the courses. Students finance their own education but financial help is available for the needy.

Philosophy of the Open University. Philosophy behind the Open University is the old democratic ideal that all are equal and all should have equal opportunity to get formal education, if they so desire. Formal credentials, distance of an institution of higher learning from a student's place of residence, and fixed time schedules should not stand in anybody's way. Thus the programs provided by the Open University have flexibility built into them. The courses are designed carefully, keeping in mind the students who may never have taken any formal education.

Organization and management. The main campus of the Open University is located in Walton Hall near Bletchley, Buckinghamshire. There are twelve regional offices, each with a director for consultation; and 300 student centers which employ almost 5,000 part-time tutors and counselors, coordinated with full-time tutors and counselors at the regional offices. Study centers are normally housed in an existing higher education institution, with rooms for meetings and tutorials, fully equipped with slide projectors, tape recorders, videotape projectors, T. V. and radio sets and other media. In addition, libraries containing complete sets of learning materials are attached to every study center. The centers are opened every evening for students who can meet with their tutors and counselors, once a week or fortnightly. In summer, for special study programs, additional staff is added at the study centers.

Programs. The Open University mainly offers undergraduate studies, but provisions are made for a small number of students to pursue graduate and post-graduate work. It also provides nondegree programs of six month duration for people who want to update their professional skills and knowledge. Initially, the main disciplines for study were liberal arts, humanities, social sciences mathematics and sciences, but two more disciplines, technology and education, have now been added.

The Open University's main originality is that it is open to all the students; no formal qualifications or testimonials are required; and there is no age, sex, or residency bar, provided the student is twenty-one year old. Degrees are granted only after the students have accumulated enough credits (six for B.A. and eight for B.A. (Hons.)), over any length of time, but requiring an equivalent of three to four years of study. The students can take a maximum of two credits each year but a part-time student can take only one credit: that is, ten hours a week, thirty six weeks a year, plus one week's attendance at the summer school. To make multi-level entrance possible, credit exemptions are allowed to students who have completed other forms of study. Students without any credit exemption must take any of the two foundation courses in mathematics, science, social sciences, arts and technology. A number of courses after the first level are interdisciplinary and the students have the freedom to make their own programs. They can take a break from their program and rejoin again.

Mode of instruction combines weekly correspondence study packages, weekly radio and TV programs and one week's summer school. Each correspondence package unit (36 in one year) consists of a set of booklets, printed notes, cassette tapes, self-study and self-testing exercises. Assignments completed by the students are mailed to their tutors for corrections. For science courses, special home experiment

kits are included. Experiments are also demonstrated on TV. All foundation level courses are supplemented by radio and TV programs. Residential summer school for one week is compulsory for all students in foundation level courses and is held on the premises of any of the conventional universities in the area.

Critique. The importance of the Open University lies in the fact that it provides opportunities to people who could never otherwise have had a chance to get higher education. It provides cheaper means: that is, education at only \$280 to \$340 per year. Adults who do not want to formally join the university can yet take advantage of the radio and TV programs free. The idea of the Open University has become very popular and is fast spreading.

#### Parallel systems of formal education

In most socialist countries, the trend seems to be to establish parallel systems of formal education for children, on the one hand, and for adults and working youth, on the other--starting from elementary education to the university. In the USSR, Poland, North Korea, such systems are already in place. China is working towards the construction of such a parallel system. (Refer to the Spring, 1976 and Summer 1977 issues of Literacy Discussion, the journal of the International Institute for Adult Literacy Methods.)

### Summary

The concept of second chance formal education is defined. Why literacy workers sometimes look at the social demand for second chance formal education as a problem is explained. The problem is also viewed briefly from the point of view of adults and youth who typically demand such educational opportunities.

The problem of program and curriculum design in the areas of second chance formal education is seen to consist of two parts: (i) designing curricula that are both relevant and equivalent; and (ii) creating delivery systems that suit the life and work patterns of adults and youth who can only be part-time or own-time learners. This has often meant innovative uses of instructional systems technology. Two such innovations are described in greater detail: the no-school school system and Britain's Open University.

### Things to do or think about

1. What level of social demand for second chance education exists in your country? How much of it is already being met? How much of it is unmet?
2. What do you know of the existing motivations which fuel this demand for second chance education at various levels? Are there significant differences in regard to motivations between older adults and youth; between male and female aspirants; and between rural and urban people?



3. Do programs exist in your country now that can be characterized as programs of second chance formal education? What kinds of populations do these programs serve? What has generally been their success or failure?

4. What is typically the technology used in these second chance formal education programs? What kinds of economic or cultural demands does this technology impose on the users?

5. Analyze the social studies curriculum in use in elementary schools of your country in regard to the vocabulary used and the concepts taught to elementary school children. In developing a relevant and equivalent program for adults what changes will you make in vocabulary and concepts, on the one hand, and in treatment and methodology, on the other. Use the following table for displaying your ideas:

	Elementary Education for Children		Elementary Education for Adults	
	Content	Treatment	Content	Treatment

Social studies:

Vocabulary

Concepts

Skills

Applications

6. If second chance educational programs have been available in your country for some years, what are the socio-economic characteristics of the populations that have availed of these programs? What has graduation from such programs meant to people in personal terms? How have these graduates fared in competition with graduates from the formal school system?

#### Readings and references

1. Antoine Kabwasa and Martin M. Kaunda (Eds.), Correspondence Education in Africa. London, U.K.: Routledge and Kegan Paul, 1973.

The editors bring together the experience with correspondence education in Africa and discuss its role in mass education, rural development and manpower training. Two major case studies are included: INADES, an experiment in several African countries that serves illiterate peasant farmers; and work in the area of cooperative education in Tanzania. The important role of media to make reciprocal communication possible is given special attention.

2. Eginio M. Chale, Mass Education by Correspondence in Tanzania. Dar-Es-Salaam, Tanzania: Institute of Adult Education, 1976.

In a short 30-page monograph the role of correspondence education to mass education in Tanzania is described and reviewed.

3. Exploratory New Directions in Teacher Education: Experiments in the Preparation and Training of Teachers in Asia. Bangkok, Thailand: UNESCO Regional Office for Education in Asia, 1976.

It is a collection of papers presented to a working

group organized by the Asia Center of Educational Innovation for Development, Bangkok. Teacher training is the focus but contributions of correspondence education to nonformal education and educational opportunity are discussed as well. Contributions have come from Iran, India, Nepal, Malaysia, Korea and Japan.

### Section 3

## Systemic Integration between Literacy and Development Objectives

---

### Organization of the section

System thinking

The need exists for systemic integration

But not to disfranchise the illiterate  
Interfaces between functional literacy and lettered  
functions

Systemic integration: literacy and economic functions

Systemic integration between literacy, political and  
socio-cultural functions

Things to do or think about

Readings and references

---

### System thinking

We should notice that in our chapter heading, we are using the word systemic (and not systematic). Systemic means having to do something with systems and system thinking.

A system is an aggregate, or a collection, or a set of things, joined in regular interaction or interdependence, serving a common function. In the physical or material world systems are relatively easier to identify, to define, even to manipulate. In the social and cultural world, however, things are quite a bit different. Social systems are not as easy to define, and to contain within boundaries;

the interdependences between their parts are difficult to discover; their functions are ambiguous; and their manipulation is a challenge to the best of social scientists and social reformers.

System thinking is a habit of thought that is essentially synoptic rather than segmented; that is, it uses a total rather than a tunnel vision to look at things. System thinking enables us to look around the entity or the process of primary interest to use and to look for its links and connections with other entities and processes around it. It enables a person to organize what may look like disparate parts into connected wholes. Thus formal education, nonformal education and informal education become parts of the same one human enterprise called education. From another perspective, education becomes a subsystem of the larger system of development.

System design is the process and method of constructing systems wherein chosen parts are brought together in planned interactions to acquire required functions and create preferred outcomes. To bring about systemic integration between and among some disparate systems is an important problem of system design. Systemic integration means purposefully bringing together two or more disparate systems into articulated mutual interactions thereby to contribute to one over-arching function. This process of articulation or building an interface between or among two or more systems is

systemic integration. Thus we can talk of systemic integration between literacy, on the one hand; and political, economic and socio-cultural systems, on the other hand, and plan for their coming together into organic relationships to serve the same overall function of national development.

The need exists for systemic integration

As we have indicated previously, the objectives of post-literacy programs are to enable new literates and other readers to retain their literacy skills, to strengthen them by reading further, and to put their literacy skills to work in their daily life. We have realized that none of these objectives have been easy to achieve. The objective of putting literacy to work has been especially difficult. This is so because putting literacy to work is an interaction which involves actions by more than one group of people. It is not something that literacy workers can do alone. To put literacy to work in political life, they need to interact with those who develop and control political institutions and implement political education programs. To put literacy to work in economic production, literacy workers need to work with those who manage the means of production. In the same way, literacy workers have to work with leadership in the socio-cultural field to develop integrations between literacy and socio-cultural aspects of life. In some cases the political, social and economic structures may have to be

changed in important ways to make them amenable to use and participation by the new literate. But in any case, deliberate actions will have to be taken to bring about systemic integrations. They have not happened on their own before; and they will not happen on their own now.

The diagram on the next page should help us visualize the process of systemic integration that we have been discussing. The figure should clarify both the process and the challenges involved in systemic integration that we have been talking about. On the one hand, literacy workers will have to make literacy functional. (And we do not mean that function used in this process has to be economic function.) On the other hand, the three functions of any society-- economic, political and socio-cultural- have to be made lettered functions. We will have to analyze us to which of our new institutions and patterns of decision making, participation and action require literacy component; and which of our traditional institutions and patterns should integrate literacy to become more responsive to new needs and realities.

But not to disfranchise the illiterate. A word of caution is necessary here. In trying to make our economic, political and socio-cultural functions, "lettered" functions, we must take care that we do not disfranchise the illiterate, in the meantime. Thus opportunities will have to be provided for use of literacy by new literates, without shutting out

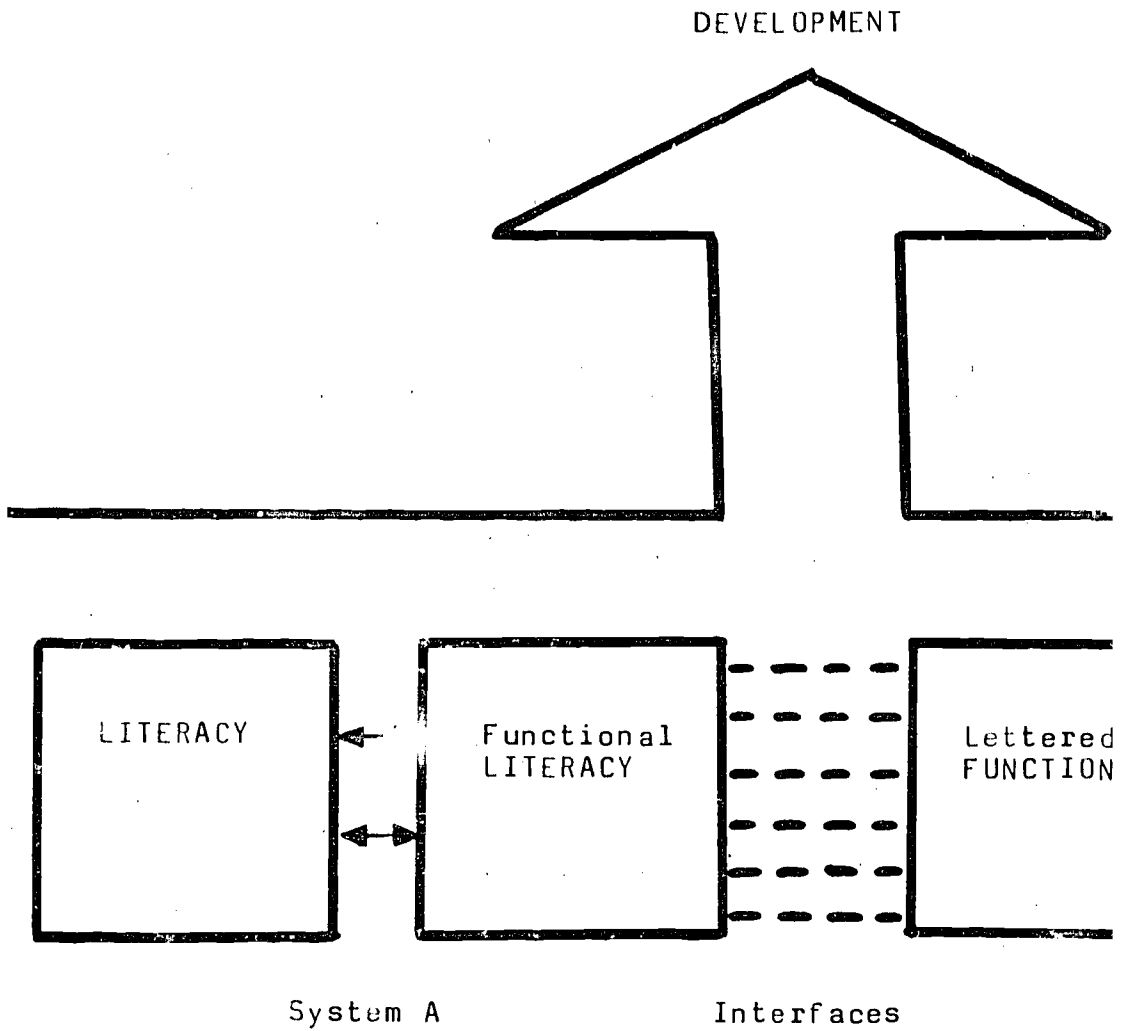

Figure 2.2: The twin needs of systemic integration: making literacy functional and making functions lettered.



the illiterates from participation. What will this mean in concrete terms is a challenge to all of us who are working in the area of post-literacy program and curriculum development. No formulas can be cited.

Interfaces between functional literacy and lettered functions. Functional literacy and lettered functions may still not come together and may need the initiative and help from planners of post-literacy programs and curricula.

Interfaces will have to be build between the two systems. This may mean the establishment of counseling and guidance services; it may mean new moles of recruitment to political and economic institutions; and, of course, it will require new ways of interdepartmental planning and action.

Systemic integration: literacy and economic functions

Over the last two decades of the 1960s and 1970s, considerable attention has been paid to delivering goods and services to those thus far excluded from the considerations of planners. It has slowly been recognized that the measure of all development is man, and that most citizens of developing countries live in the rural areas. Many programs have been designed to deliver education and health services to these rural people; in some cases too little and too late. Programs of rural employment and income are being developed; cooperative structures are being built and people in some places are being enabled to participate in their political

institutions. The job is by no means done; but the first few steps on the long journey have been taken.

But it must be said quite clearly that the two tasks of what we have called (i) lettering the functions and (ii) building interfaces between functional literacy and lettered functions both remain to be done to a considerable degree. Indeed, it is difficult to report instances from literature which show deliberate attempts to accomplish either of these tasks. Fortunately, there are lots of eligible cases; programs of economic, social and political development that have been tried and have been found to be more or less successful. Post-literacy program planners should latch on to such programs for mutual good, and to promote real development.

It is not within the scope of this workshop manual to include detailed descriptions or critiques of these programs. We will be satisfied with listing or referring to such programs. One useful source of such programs is Manzoor Ahmed and Philip H. Coombs (Eds.), Education for Rural Development: Case Studies for Planners. The following tabulation illustrates the diversity of programs contained in the case studies included in this book:

---

<sup>1</sup> Manzoor Ahmed and Philip H. Coombs (Eds.), Education for Rural Development: Case Studies for Planners. New York, N.Y.: Praeger Publishers, 1975.

<u>Learning Objectives</u>	<u>Major Clienteles</u>	<u>Programs</u>
1. General education literacy, numeracy, change-motivation, development-orientation)	Rural youths and adults	ACPO in Colombia; Functional Literacy Programs in Mali and Thailand; Sarvodaya in Sri Lanka
2. General education plus occupational orientation and training (including elements of both farming and nonfarm occupations)	Early drop-outs from formal schools, primary school leavers, youths in formal institutions	Cuba's Schools-in-the-Countryside; Jombang Project in Indonesia; Youth Camps and Youth Centres in Jamaica; Village Polytechnics, National Youth Service, and Youth Centres in Kenya; COPS in Mali; Diyagala Boys' Town in Sri Lanka; prevocational courses in Sri Lanka secondary schools; Rural Education Centres in Upper Volta
3. Improvement of family life (health, nutrition, home economics, family planning, etc.)	Rural adults, women and girls	ACPO in Colombia; Women's Organizations in Kenya, Mali, and Sri Lanka; literacy and family life program in Thailand; Sarvodaya Movement in Sri Lanka
4. Training in farming and allied sideline production	Youths and adults in rural families, rural out-of-school youths	PACCA in Afghanistan, SENA-PPP-R in Colombia, ORD programs in Korea, Jombang Project in Indonesia
5. Training in rural non-farm skills	School leavers and other adolescents, rural adults employed in nonfarm occupations	SENA-PPP-R in Colombia; mobile skill training and cottage industries programs in Sri Lanka; Rural Industries Projects in India; Vocational Improvement Centres in Nigeria; Mobile Trade Training Schools in Thailand
6. Training for small entrepreneurship and management	Workers and owners of non-farm enterprises, unemployed educated adults	Rural Industries Project and Entrepreneurship Training Programs in India; Vocational Improvement Centers in Nigeria

<u>Learning Objectives</u>	<u>Major Clienteles</u>	<u>Programs</u>
7. Training for village level leaders, amateurs, and extension workers	Extension officers; new recruits for animation and extension work; village youth and women leaders; cooperative officers; unemployed educated youth	CARs in Mali; Sarvodaya in Sri Lanka; National Youth Services in Sri Lanka; ORD and 4-H Programs in South Korea; IRRI Extension Training Program in Philippines; Tanzania's Cooperative Education Program

An earlier book (Non-Formal Education in African Development by James R. Sheffield and Victor P. Diejomoah, African-American Institute, New York, 1972) had conducted a survey of nonformal education in Africa that included Kenya, Tanzania, Uganda, Ethiopia, Zambia, Botswana, Ghana, Upper Volta, Ivory Coast, Camerouns, Dahomey, Senegal, Nigeria, Tunisia and Morocco. It reported on projects of various kinds and objectives that covered cottage industries, agriculture, cooperatives, health and family planning, vocational and industrial training, management skills and much else.

The Report of Conference and Workshop on Non-Formal Education and the Rural Poor by Richard O. Niehoff and Kenneth L. Neff (Michigan State University, 1977) also presents several case studies of nonformal education from countries all over the world ranging in their interests from nutrition, health and family planning to cooperatives, income generation and rural public works.

<sup>1</sup>Ibid., p. xxix-xxxii.

Two issues of The NFE Exchange (Issue No. 11/1978/1; and Issue No. 16/1979/2) have dealt respectively with the subjects of "Skills Training Programs for Adults" and "Generating Income Through Group Action." Both have reported thumb-nail sketches of interesting and innovative field projects: the Lentswe La Oodi Weavers project in Botswana; the work of the Plateau Board for Integrated Education for Development in Jos, Nigeria which works with the handicapped and other villagers; the Mixed Vegetable Scheme in The Gambia; the Partnership for Productivity scheme of Kakamega, Kenya; The multi-faceted Biriwa Project in Cape Coast in Ghana; and several similar projects from Asia and Latin America.

In the preceding, we have presented lists of nonformal education projects which have an economic bias: these projects seek to increase productivity; provide skill training and experiment with different modes of income generation through employment and self-employment. One does not, however, come across cases where deliberate attempt has been made to make these economic functions "lettered," make them amenable to literacy. One does not come across examples of diagnosis of the needs in respect to economic functions to be met specifically through a program or component of literacy. If anything, the trend seems to be: "Let us get on with the job of training and earning and producing; literacy will come if and when necessary." In extreme cases,

the assumption is made that participants are already literate and since they are often not literate, training collapses. There clearly has been a failure in the systemic integration between literacy and economic functions.

Systemic integration between literacy, political and socio-cultural functions

Once, again, a number of nonformal (adult) education programs in areas of health (see Issue No. 15/1979/1 of The NFE Exchange and Issue No. 27/July 1979 of the Development Communication Report for brief reports on field projects); family planning (see David Harman, Functional Education for Family Life Planning, II: Designing a Program, World Education, New York, 1972); political education (in Cuba, Tanzania, Zambia, for example); and folk arts (as in India and Botswana to mention only a few) have appeared in the development horizon. Once, again, however, work in literacy and work in these various areas has been conducted in two parallel streams. The political, and socio-cultural functions have not always been made lettered functions.

Things to do or think about

1. Think of the community that you have known for a year or more. Do men, women and youth already literate have sufficient opportunities to put their literacy skills to functional uses in economic, social and political arenas? What would improve the situation? What could you do to bring about a more satisfactory situation?

2. Have you or your department recently designed a post-literacy program or curriculum with a clear and direct objective of promoting integration with an economic or political mechanism or structure in the community? What is this program or curriculum like.
3. What could be done to enable literates in rural communities to improve their family incomes?
4. Think of a program (not necessarily from your community) where the integration between literacy and some social, economic or political function has been ideal? How do you explain this success?
5. In a recent seminar, the following steps were proposed to promote systemic integration between literacy and development functions at the community level. Critique this proposal:
  - (a) Taking a census of existing social, economic and political structures in which new literates (men, women and youth) could participate.
  - (b) In collaboration with the appropriate authorities and leadership groups, taking steps to design needed new structures and mechanisms that would make it possible for new literates to become active participants in their own communities.
  - (c) Analyzing the objectives, modes and tasks of the various socio-economic and political structures to determine how literacy could make participation more widespread and more meaningful. (We will have to ensure that i trying to

promote participation by literates in these structures, we do not shut out whatever participation is coming from the illiterates of the community at present. Of course, we should remember that some illiterates are able to participate somehow in the social, political and economic structures of their communities, sometimes quite effectively.)

(d) Finally, and most importantly, preparing the presently naive participant for effective participation in these structures and mechanisms. This is primarily the task of the planner of the post-literacy programs. But it is useful to remind ourselves that all of these tasks may have to be undertaken in collaboration with other developmental workers in the community; and some may have to be done completely by others, with initiatives from the post-literacy program planner.

#### Readings and references

Please see the body of the section for references.



Section 4Socialization for an Ideal Society

---

Organization of the section

Independent learning and praxis  
Mass media appreciation  
Technology awareness  
New international order  
Understanding the human environment  
Things to do or think about  
Readings and references

---

Caught in the immediate, day-to-day problems of helping the poor, the sick, the unlettered and the unemployed, the objective of socializing adults and youth for an ideal society may seem to be too idealistic and somewhat distant to most literacy workers. Yet, in a very real sense, this objective is both significant and urgent. Our image of the ideal society, howsoever remote, determines what we teach and what services we deliver. More importantly, to invite democratic participation, the vision of the ideal society must be shared with the adults and youth we seek to serve; and they must be enabled to understand the society they can aspire for and the world order they must have. At a more concrete level, they must understand the tools and

technologies of the modern world which, in the hands of the powerful, have much too often misled, narcotized and exploited us and alienated many of us from our own communities and cultures.

What is an ideal society? What kind of a new world order should we have? What are the tools and technologies of the modern world which are oppressing us? By way of an answer, we offer the following quote:

By "major contemporary problems" should be understood not only questions which may be regarded as political or economic--such as the exercise and defence of human rights, peace, international understanding and co-operation, the attainment of full national independence and equality of peoples, the struggle against all forms of racism, the unequal distribution of the world's resources and wealth (the new international economic order), problems of energy and raw materials--but also social and cultural issues--such as the assertion of national and ethnic identity and the identity of minority or marginal cultures, the questioning of systems of values, the struggle for social justice, changes in the status of women, the preservation and improvement of the environment and quality of life, adaptation to the changes brought about by the rapid development of science and technology, life-long education, professional retraining requirements and social mobility.<sup>1</sup>

The major contemporary problems listed above will demand a most exhaustive educational agenda from program and curriculum planners in post-literacy stages. We have discussed a large part of this in the preceding three sections. Here, we will focus on the following five program and curriculum themes:

---

<sup>1</sup>The Canadian Commission for Unesco, Symposium on Improving the Contribution of the Mass Media to Adult Education (Ottawa, Canada, October 1-5, 1979). Occasional Paper #35. (See "Discussion Guide," Annex 2, para 3.)

1. Independent learning and praxis
2. Mass media appreciation
3. Technology awareness
4. New international order, and
5. Understanding the human environment

1. Independent learning and praxis

The ideal society in a new world order, demands a learning society and a participant society. We must have independent learners who, on their own, can define problems and engage in a knowledge search to understand and to solve them. Where commitment and action are required, they should be able to engage in individual praxis--the never ending cycle of action and reflection contributing to a moral social order.

What kinds of programs and curricula can be offered for independent learning and praxis? It is quite clear that such programs have to be enabling programs where the educator acts as a peer and a catalyst. It may also be worthwhile to remind ourselves at this stage that the post-literacy planner has to act as an "adult educator" in the widest meanings of the phrase. Some of the programs he designs may be based on print media; but others may be based on nonprint media. While using nonprint media, the program planner need not make assumptions of illiteracy among his participants, though he may make special provisions for those participants who are indeed illiterate.

It is difficult to come across in literature many examples of programming that teach people to become independent learners or seek to sustain their praxis. Most literature, interprets independent learning as a visit to the library. We do not know much about problem-oriented knowledge search by new literates in different societies. Indeed, we are not clear about what expectations to have in this regard. We know, of course, of Paulo Freire's cultural circles for illiterates that sought to raise their consciousness and thereby sought to promote individual praxis. There is no reason why we can not have cultural circles for new literates as well in the post-literacy stages, but these do not seem to have been tried anywhere. The possibilities for program development in this area are challenging. There is scope for some pioneering.

## 2. Mass media appreciation

The new mass media--radio, film, and television--have today created a new, invisible, all-pervasive, symbolic environment which we all breathe as we breathe the invisible air. And as the air is in our blood, so the media are part of our consciousnesses. No thinking individual on this globe is outside the direct or indirect influence of the media. Therefore, "it appears essential today to provide all adults with the information, tools, opportunities and support which will enable them to develop an alert disposition towards radio and television. They will thus be conscious of the

fascination and power that these media exercise, capable of using them spontaneously in their daily lives without surrounding them with a magical aura, and prepared to see through or place in true perspective the artifice and trickery which may be used; in sum, they would always be forearmed to retain mastery of the medium."<sup>1</sup>

Whether we like it or not, the media of film, radio and TV, have become the most important part of the popular culture of the 20th century. The following tables, adapted from Unesco's Statistical Yearbook: 1977 provide some impressive data. While only a few developing countries in Africa, Asia and Latin America are producers of long feature films, all of them are heavy importers of these "dreams in culluloid." In 1976, Benin imported 331 films, Kenya 337, Uganda 200, Tanzania 176. There were three and a half million visits to the movies in Tanzania that year; and there were 5.7 million visits to the movies in Kenya. In India, there were a staggering 2,260 million visits to the cinema houses. Ownership of radio and television sets is also fast increasing.

In most parts of the developing world, adult educators are complaining loudly about cultural imperialism, psychological dependency and alientation being engenerated by the media, especially the media imported from the West. Yet adult educators and post-literacy workers have continuously

---

<sup>1</sup>Ibid., page 9.

Table 2. Fixed cinema, total seats and seating capacity per thousand inhabitants (1975)

Countries made (1976)	Number imported (year)	Total attendance in millions per year
Algeria	436 (1974)	
Benin	331 (1976)	1.2
Botswana	208 (1975)	0.1
Ethiopia	333 (1974)	
Kenya	337 (1976)	5.7
Libya	210 (1975)	23.0
Uganda	200 (1976)	1.3
Cameroon	760 (1974)	
Tanzania	176 (1976)	3.5
Mexico	514 (1975)	251.2
Peru	307 (1975)	
Bahrain	764 (1974)	2.0
Indonesia	400 (1975)	112.5
Iran	563 (1974)	
Malaysia	909 (1975)	
India		2160.6

From Statistical Yearbook: 1977, Paris, France: Unesco, 1978.

Continents, major areas and groups of countries	Fixed cinemas in thousands	Total seats in millions	Seating capacity per thousand inhabitants
World total**	267	77	25
Developed countries	235	58	52
Developing countries	32	19	9.7
Africa	3.1	1.9	4.8
Asia	21	12	6.6

\*\*Not including China, the Democratic People's Republic of Korea and the Socialist Republic of Viet-Nam.

Adapted from Statistical Yearbook: 1977, Paris, France: Unesco, 1978.

Table 3. Radio and TV receivers in absolute numbers and per thousand inhabitants

Continents, major areas and groups of countries	Absolute numbers				Per 1000 inhabitants				
	1965	1970	1975	1976	1965	1970	1975	1976	
World total**	Radio	524	672	931	933	207	241	303	305
	TV	161	266	370	384	72	96	122	123
Developed countries	Radio	460	572	770	708	449	553	647	606
	TV	170	244	334	341	166	227	298	301
Developing countries	Radio	64	100	161	165	42	50	63	63
	TV	11	22	46	43	7.3	13	21	22
Africa	Radio	16	16	28	30	33	45	70	72
	TV	0.6	1.2	2.5	2.8	1.9	3.4	6.2	6.8
Asia	Radio	42	56	108	113	39	48	80	81
	TV	15.3	27.0	33.2	36.3	18	22	27	28

\*\*Not including China, the Democratic People's Republic of Korea and the Socialist Republic of Viet-Nam.

Adapted from Statistical Yearbook: 1977, Paris, France: Unesco, 1978.

and consistently neglected programs of media appreciation. Where film forums, radio forums and lectures have been organized, the focus has been exclusively on instructional film, and educational radio and TV. Post-literacy workers need to make beginnings in organizing forums and discussions around feature films, entertainment radio and commercial TV in cities and, where relevant, in rural areas. These programs must be discussed as honest expressions or distortions of social reality. Listeners and viewers may also be provided experience in codifying their own realities on film and tape through such strategies as "local radio" and "community TV." There is no excuse for neglect or delay.

3. Technology awareness

Another important area, neglected by planners of post-literacy programs and curricula is that of technology awareness. Technology is a part of our lives everywhere in the world. And yet its pervasiveness is matched by the pervasiveness of our ignorance about it.

We should build intelligent and sensitive courses dealing with understanding the scientific aspects of our lives, the nature of technology--old and new technology--and the role and reasonableness of intermediate technologies in our parts of the world."

4. The new world order

The existing world order is an unjust world order.



It is divided between the have's and the have-not's. There are structural realities, imposed by the powerful nations, which continue to exploit the already exploited and make them even more dependent on the outsider. The existing world order is in immediate need of repair.

But what have new literate adult men and women working on farms and in factories got to do with these big ideas? Can't we leave these to our ministries for foreign affairs? We must realize that the new world order is not a battle between the elite groups in various developing and developed countries, it has to become a universal vision and a mass movement all over the world.

The following ideas must become part of the common knowledge of each and every individual alive in the world:

- of the common brotherhood of man;
- of the dignity of each and every human being and of the sanctity of all races and ethnic groups;
- of the richness of each individual culture;
- of colonial history in which man exploited man for his own greed, a situation which need not continue;
- of the unjustness of high level of consumption in one society and hunger in another, and the need to remedy this through collective action;
- of the rules of the game (in trade, in politics) that are rigged against the weak, which must be mended through solidarity and self-reliance; and

- of the need to create a new community in which all can fully and equitably partake of the bounties of the earth.

#### 5. Understanding the human environment

Interrelated with the ideas of technology awareness and the new global order is the need to understand and protect the human environment. Unesco's Learning to Be (1972), puts the problem in words that are hard to match:

### Environment in peril

Technological development has enabled man to solve many problems, but it has had harmful effects on a number of aspects of contemporary life. All over the world, it contributes to environmental deterioration.

This deterioration does not date from yesterday. During his 7,000 years of recorded history, man has had to tackle the environment and control it. But, through carelessness or ignorance, he has at times impoverished it. Fire, used for hunting and itinerant agricultural purposes, laid forests bare. Irrigation of arid regions increased salinization, which later led to the loss of cultivable land when drainage was inadequate to carry salts away from the irrigated zone. In North Africa and the Middle East, this process turned much formerly fertile land into desert.

Since the nineteenth century, spoiling processes have gathered speed as populations increased and industrialization developed. In former times it took centuries to exhaust fertile land; now a few decades are enough. In North and South America, as in Africa, intensive forest clearing, together with the disappearance of grass and other vegetation covering the soil, have led to erosion, floods and drought. The soil, no longer protected, is blown or washed away.

*Disorderly  
expansion*



According to United Nations estimates, 'Five hundred million hectares (1,235 million acres) of arable land have already been lost through erosion and salinization, two thirds of the world's forests have been lost to production and 150 kinds of birds and animals have become extinct because of man. Approximately 1,000 species or races of wild animals are now rare or in peril. Erosion, soil deterioration, deforestation, watershed damage and the destruction of animal and plant life continue and in some areas are increasing'.<sup>1</sup>

The growth of cities has aggravated this destruction. In the United States, some two hectares (five acres) of land per minute are absorbed into highways, urban expansion, airports, car parks and other 'modern requirements'. Forty per cent of the world's population now live in urban areas. If this trend continues, by the beginning of the twenty-first century about three-quarters will be living in urban areas overflowing their present limits, merging into each other to form 'megalopolises' of the kind stretching from Boston to Washington or from Tokyo to Yokohama.

*Ecological  
disequilibrium*

Until the nineteenth century, towns remained in direct, fairly close contact with the countryside or the sea, enabling man to satisfy his physiological and psychological needs. With the advent of industrialization, urban development was solely a function of economic or political imperatives, in the belief that man was master of his environment and capable of liberating himself from his natural biological limits.

The consequences of that disorderly expansion are now upon us: pollution of the air, the soil, lakes and seas; physiological and psychological disturbances; calm a memory, violence a constant menace. Noise—upsetting city-dwellers at work, in the streets and at home—interferes with mental concentration, provokes a new form of fatigue<sup>2</sup> and increases the risk of vocational illness and disorders, such as deafness. As the cities become more over-populated and anonymous, so man becomes more nervous and aggressive.

The developing countries, it would seem, have yet to learn this from the industrialized societies' experience. They have permitted (or solicited) elements derived from a totally different technological

1. U Thant, 'Man the Killer of Nature', *Unesco Courier*, p. 48, August-September 1970. See also, *Use and Conservation of the Biosphere*, Paris, Unesco, 1970.
2. According to Constantin Stramentov ('The Architects of Silence', *Unesco Courier*, p. 10, July 1967), studies in post offices showed that when the noise level rose from 75 to 95 decibels productivity immediately dropped by 25 per cent, while mail-sorting mistakes increased fourfold. When acoustic sound-screens placed round workers lowered noise-levels by 10 and 15 decibels, however, productivity increased by 5 and 18 per cent respectively.

universe to invade their accustomed way of life, speeding their 'development'. Its dualistic nature seems to be forcing them into a pattern of life in which they are becoming increasingly insensitive to the dangers of cultural and ecological disequilibrium. This phenomenon has already dragged many developing countries into a situation in which pollution of their towns and cities and, especially, the irreversible deterioration of their vital countryside are destroying the natural harmony of the setting in which their own culture has evolved over the centuries.

It is not only man's environment but—in the near future—his very fate which may be threatened, and he has already begun to suffer. Rapid changes are winding up tension in people, increasing insecurity, nervous disorders, antisocial behaviour, delinquency and criminality.

*Technology has already produced gross harmful effects. It has jeopardized and is still disturbing the balanced relationship between man and his environment, between nature and social structures, between man's physiological constitution and his personality. Irreversible ruptures are threatening mankind. The job of confronting these multiple dangers falls largely on education. Work to remedy the situation involves an all-out attempt to prevent such division, to forestall and counteract the dangers deriving from the technological civilization. Stimulating awareness of such dangers is a demanding new task for education, but particularly appropriate to it for many reasons and, too often, one that is much underestimated.*

### Things to do or think about

1. Each culture seems to have its own unique view of an ideal man, delineating his duties and responsibilities, his relationships with other men, nature and destiny. Hindus have their concept of Dharma. The Thais, in recent years, have made the concept of the Khit-pen man as a cornerstone of their nonformal education programs. What is the concept of a man of wisdom in your culture? What is your ideal of a man in society?
2. What kinds of problems are our new literates and youth likely to come across in their daily lives? What kinds of

information they will need to solve them? Is such information available in their immediate surroundings?

3. What do you know about the film and TV viewing habits of people in your country?

4. Does your country import films and TV shows from America or other sources in Europe and Asia? Are these imported films and TV shows quite popular? What, in your opinion, are some of the social effects of foreign imports on viewers? Do you think these adult viewers might be interested in getting together in films discussion groups or teleclubs to discuss their experiences?

5. What are the possibilities of introducing film appreciation courses or experiences in your urban (and sometimes later, in rural) schools?

6. Have you recently seen a film or a TV show that could be used to great advantage to discuss some important social issues confronting the country?

7. What kinds of entertainment programs of music, drama, talk show are produced over the radio? Are these programs good? Are they harmless? Are they seriously distorting social reality?

8. Are some of your own colleagues in the field of literacy and adult education comfortable in and with the scientific culture? How can we develop technology awareness among ourselves before going to teach it to others?

9. How much of what we eat, wear, or otherwise use at home

and at work or for getting to work is imported? Where is it imported from? What do we have to give to those who sell these things to us?

10. How can we communicate the concept of interdependence and of injustice of some of the national and international structures to new literates?

11. Jomo Kenyatta once said, "Let us forgive but not forget." How to develop a post-literacy program to promote new global order that educates and generates commitment without merely creating anger and violence?

12. What are some of the local problems in the community that can be attributed directly to environmental deterioration? What can the community do about those problems? How to get help to do the part that the community can not do, left to itself?

#### Readings and references

Final Report of the International Conference on Film, Television and Society in English Speaking Africa, Bonn: German Foundation for International Development, 1971.

Edgar Faure and others, Learning to Be, Paris: Unesco, 1972.

H. S. Bholra, Celluloid in Indian Society, New Delhi: Indian Adult Education Association, 1961.

This small monograph reviewed the feature films released on the commercial circuit in India during the period of 1947 (the year of Independence) and 1960 and showed how those films had or had not succeeded in projecting and

interpreting social realities of India during those two most important decades of post-independence India. Suggestions were made on how those films could be used in discussion groups to discuss a variety of social issues, political issues and problems of nation-building, in general.

Henry T. Ingle, Communication Media and Technology: A Look at Their Role in Non-Formal Education Programs. Washington, D.C.: Academy for Educational Development, 1974.

Richard C. Burke, The Use of Radio in Adult Literacy Education. (Literacy in Development Series, H. S. Bholra, Editor), 1976.

T. Coleman, A. Opaku and H. Abell, An African Experiment in Radio Forums: Ghana, 1964/65. Paris: UNESCO (Reports and Papers on Mass Communications, No. #51, 1968).

E. G. McAnany, Radio's Role in Development: Five Strategies of Use. Washington, D.C.: Clearinghouse on Development Communication, 1976.

## CHAPTER III

PROGRAM AND CURRICULUM DESIGN:  
A PRACTICAL MEMORANDUM TO PLANNERS AND IMPLEMENTERS

---

Organization of the chapter

## 1. Grasping the national vision

Things to do or think about  
Readings and references

## 2. Understanding the change process

The role of literacy and post-literacy programs in  
the overall development strategy  
The role of literacy workers vis-a-vis other development  
workers  
The role of literacy workers at the various levels of  
the administrative system  
Things to do or think about  
Readings and references

## 3. Organizational design and institution building

Things to do or think about  
Readings and references

## 4. Needs analysis and community diagnosis

Things to do or think about  
Readings and references

## 5. Counselling and guidance for adult learners

Things to do or think about  
Readings and references

## 6. Program and curriculum design issues and skills

Reaching the specially disadvantaged

Working with women

Participation and institutionalization  
Things to do or think about  
Readings and references

## 7. Evaluation in the post-literacy stages

Evaluation needs in the post-literacy stages  
 General evaluation approaches and techniques  
 Things to do or think about  
 Readings and references

## 8. Training of personnel for planning and implementation of post-literacy programs

Some approaches to training  
 Things to do or think about  
 Readings and references

In Chapter II, we presented, what we called, "a catalog" of program and curriculum needs of adults and youth in the post-literacy stages. Four general sets of needs were identified: (i) programs and curricula to help in literacy retention; (ii) programs that offer adults and youth a second chance for formal elementary, secondary or higher education; (iii) programs that build connections between literacy and its use within economic, social and political settings to promote the integration of marginal or excluded adults and youth within the economic, social and political structures of the society; and (iv) programs that prepare adults and youth for life within the emerging global community.

We also indicated in Chapter II that none of these four sets of needs are being fully met in most of the Third World countries. Some of these needs are indeed in dire neglect. For example, while most Third World countries have now become aware of the need for providing follow-up reading

materials to new literates, too little has been achieved in actually producing and distributing such materials. Hardly any thought has been invested in designing and implementing programs that we characterized as programs of systemic integration; that is, programs that will offer new literates participation in the social, economic and political institutions relevant to their lives and work; help new literates to understand and to contribute to these institutions; and prepare them to demand that those institutions become responsive to their aspirations and needs. A review of the international experience included in the chapter bears this out quite well.

How to design and implement an appropriate and effective network of programs and curricula to serve new literates (and other readers) in the post-literacy stages? This is the question to which we must turn in this final chapter of the workshop manual.

Understandably, it will be impossible to offer blueprints ready to implement. Each country will have to be considered as a unique system of aspirations, needs, resources and possibilities; and a network of programs and curricula will have to be designed that is appropriate to that particular society at a particular time in history.

What we will emphasize in this chapter is process of planning and designing. We will discuss some general considerations for planning and designing programs and



curricula in the post-literacy stages; we will discuss important program elements that may be necessary in innovative planning in this area; and we will discuss some of the skills needed by literacy workers for them to be able to engage in planning and implementing programs and curricula in the post-literacy stages.

### 1. Grasping the national vision

In designing post-literacy programs and curricula, we are engaged, of course, in the nation's business. We are engaged in designing educational programs that will contribute to the overall national goals. It is self-evident that we should be clear about the national goals as we seek to make our special educators' contribution to nation-building and development. Yet, this is something that is not always done. In our anxiety to take immediate steps, we may forget to look at the horizon to establish the relationship between our overall goals and our immediate tasks; and sometimes we may start on an easy beaten path, but in the wrong direction.

Grasping the national vision will mean understanding both the national objectives and the grand strategy being promoted in the country. Unfortunately, national visions are not always clear. Some nations may be said to have blurred national visions at best; they may have no clear idea about national objectives or strategies; and may be too quick to compromise goals and actions to solve immediate problems. The tasks of a literacy worker in such settings are difficult

and highly demanding. This might even mean that the literacy worker will have to develop his or her own sense of where the nation should be heading and to choose to teach values and skills that could never do harm.

In most other cases, statements of national goals and strategies will be available in planning documents of some sort or speeches and pronouncements of the leadership. An understanding of the goals and strategy calculus is bound to make the program planning and curriculum designing task rational, meaningful and innovative. The national vision and the cultural ethos will demand different justifications for programs of post-literacy. In one country, the programs may be justified in terms of economic returns; in another they may be justified in terms of political socialization for a new social order. Both the structure and content of programs and curricula will be significantly effected depending upon whether the justification used is economic or political.

National visions and the approved calculus of goals and strategies will also determine how things are done. Should the programs be designed on the assumptions of voluntary participation or compulsory attendance? What will be the modes of mobilization of the people to make participation in post-literacy work, a national movement? What forms of institutions will be preferred and how will available incentives be managed?

\* Literacy workers in their post-literacy programs can not be building bridges to nowhere. They must know what the national visions are and must relate their programs and their curriculum content to the actualization of those visions whatever their level of responsibility within the national system. Comprehension of the national vision is as important for the central planner as it is for the field worker.

#### Things to do or think about

1. What, in a few words, is the national vision of the future held up in your country? What does it imply in terms of goals and in terms of strategies, that is, in regard to the ways of doing things?
2. Do you expect programs and curricula for the post-literacy stages to be different, from each other, in such countries as Cuba, Tanzania, Brazil, Kenya and India? If yes, in what ways?
3. What is a program or a curriculum already in use in your country in the post-literacy stages that you think is unique to your country?

#### Readings and references

Paul E. Sigmund (Editor), The Ideologies of the Developing Nations. New York, N.Y.: Praeger Publishers, 1972.

The book brings together excerpts from the speeches and writings of the great leaders of the Third World countries including Mao, Lin Piao, Nehru, Sukarno, Gandhi, Nasser,

Bouguiba, Sekou Toure, Senghor, Nkrumah, Nyerere, Castro, Allende, among them.

## 2. Understanding the change process

The planner of post-literacy programs and curricula is a change maker. He is making his special educational contribution to the overall change and development effort of the nation. At a societal level, he may be educating new literates and youth to become independent and critical consumers of information, and world citizens by mentality. At the sectoral levels, he may be educating and informing people about improved agriculture, preventive health measures, family planning, nutrition and how to run cooperatives. He may not be carrying the whole burden, but he will be performing important educational tasks without which development and change will be impossible to bring about.

### The role of literacy and post-literacy programs in the overall development strategy

While the definitions of "development" differ from one society to another, the dimensions of development (or change) remain the same. The elite in each society, using different ideologies, create different visions for their peoples. These visions involve new distributions among classes and individuals of political power, of social status and of economic goods.

Economic goals almost always involve more production; and economic strategies some rationalization of instruments of production, and a higher level of technology. This means for adults and youth learning new aspirations, new skills, and new ways of organizing. This also means education, which in most developing countries today, means literacy acquired in an adult literacy class and retained and strengthened in suitable post-literacy programs. This is so since the formal system in most developing countries is not old enough to have served the needs in the past and is not extensive enough to serve the needs in the present.

Similarly, political goals of development must inevitably involve new distributions of power in the society. Citizens share in power by participation in decision-making within the institutions surrounding them. To be effective as a participant one must have the necessary communication skills, knowledge of rules and the possibilities of action to demand that those institutions become responsive to the real needs of participants. For this, again, we need education within post-literacy programs and curricula. Finally, to acquire new status in a new social order, means a new self-concept, a new social consciousness and experience in new ways of relating with other individuals from different social classes. All this can not be achieved without a strong and significant educational component. No wonder, education has often been equated with development. The role

of literacy and post-literacy programs in the overall development effort should thus be apparent.

The role of literacy workers vis-a-vis other development workers

When we sometimes equate development with education, we do not intend to be taken literally. We are being somewhat poetic. We are exaggerating to impress upon our readers the important role of education in development. We are not saying, however, that all we need for development is to educate and to do nothing else. That is clearly not true. We need many different types of inputs in development; and we need to build the needed material infrastructures to create and sustain development.

Education (in our case literacy and post-literacy programs) means only the one wheel of the developmental cart. To roll properly, the cart needs both its wheels; neither the one, nor the other is dispensable. This is an important lesson for post-literacy planners to learn. There is very little they can do all by themselves. They have to depend upon cooperation from others in agriculture, health, cooperatives, housing, labor, commerce and industry, the religious establishment, the media, publishers, and voluntary institutions to do their tasks.

Thus the planning objectives of designers of post-literacy programs consist actually of two parts: (i) what should the literacy workers do themselves by way of program

planning and implementation; and (ii) what should they get done through collaboration with others. The (ii) above is as important as (i).

To plan for post-literacy programs in collaboration with others requires both a mind-set and organizational skills. The post-literacy program planner must internalize the belief that his work will never get done in isolation; that he needs to collaborate with others; but that it is his duty to take the initiatives to bring everyone together. In other words, our planner should become an "adult educator" to his colleagues in other departments and sectors, training them to think and act in system terms.

The systems view and the accompanying mind-set for collaboration are not enough. The post-literacy planner must understand the world of organizations. He must know why different ministries and departments fight over jurisdictions; why they want to plan alone and in isolation; why budgets are never common; why each department wants to have their own fleet of cars and landrovers; why individual workers want to be working at the headquarters or at least in their own department, rather than on secondment in a joint project office, and so on.

The post-literacy workers will also have to learn the skills for creating temporary administrative systems, advisory committees and coordination committees and must learn to make them effective. (For a discussion of these issues see the Technical Appendices.)

The role of literacy workers at the various levels of the administrative system

Who do we mean when we talk of post-literacy planners and designers? Those top people in the ministries and in the regional offices? The answer is that those are not the only people we have in mind. We are talking of a total planning and implementing "administrative culture" which includes, on the one hand, planners in the planning department and, on the other hand, the village level workers at the front line of social action among communities. And we mean to include every one in-between: the district officials, and division and ward level literacy workers. As they read the materials included in this workshop manual, they should delineate their particular role from their particular situation. We may all be doing different things at different times, but we will all have to pull together and make our special contributions, for the tasks to get done at all.

Things to do or think about

1. What is your personal model of planned change? In other words, how do you think change can be brought about through planful actions? What role do you assign to education (of the type to be made available through post-literacy programs) in your planned change model?
2. What are some useful collaborative arrangements that are possible to bring about some innovative post-literacy programs?



3. What is your favorite story of inter-ministerial conflict when two ministries worked at crosspurposes and forgot about the task on hand? What is your favorite story of excellent inter-ministerial collaboration? Analyze the causes in both cases.

4. Do you think lots of inter-departmental committees are a waste of time? What are the alternatives? If we can not do without such committees, how can we make committees more functional, efficient and enjoyable?

#### Readings and references

H. S. Bholā, Social Change and Education, Morristown, New Jersey: General Learning Press, 1976.

H. S. Bholā, "Notes toward a Theory: Cultural Action as Elite Initiatives in Affiliation/Exclusion." Viewpoints (Bulletin of the School of Education, Indiana University), May 1972, pages 1-37.

Amitai Etzioni and Eva Etzioni, Social Change-- Sources, Patterns, and Consequences. New York: Basic Books, 1964.

#### 3. Organizational design and institution building

To get action, we must organize. To get consistent action over a long period of time, we must create institutions.

The two words, 'organization' and 'institution,' are often used interchangeably. Institution can be seen to be an organization that has struck deep roots in the society; has come to serve and to be seen as serving an important need for the society; and has become, in a sense, indispensable to the social system. To use an analogy, organizations are like

private buildings, whereas institutions are like public monuments.

At the post-literacy stages, the essential objectives of planners are to create arrangements, mechanisms and patterns which will continue to provide new literates and new readers with opportunities to continue reading and putting what they read to functional uses. While instruction (curriculum development) is still important; equally important is the aspect of developing organizations. Organizational design and institution building are indeed crucial at this stage. Without an understanding of these processes, planners of post-literacy programs and curricula simply cannot succeed in the achievement of their objectives.

There is no dearth of references to the need for institution building in the literature of literacy and adult education. Various national and international symposia, over the last ten years, have pointed to the need for institutionalization of literacy and post-literacy work. A Unesco seminar in Nairobi, Kenya in 1976 addressed itself to the theme of structures for literacy and adult education. Yet, regretfully, the "organizational literacy" of most literacy workers remains quite inadequate. It is for this reason that we have included in this workshop manual a Technical Appendix on organizational design and institution building.

### Things to do or think about

1. Most of us have spent good parts of our lives working within organizations and have thus experienced them at first-hand. Try to put on paper five things that you have come to know about organizations and people within organizations that post-literacy program planners should keep in mind.
2. What mechanisms exist for your organization to coordinate work vertically across levels from the center to the field and horizontally across different departments such as education, agriculture, health and housing, etc.?
3. What indigenous social organization in your community could be used to undertake the new developmental and educational tasks that we have in view as post-literacy workers, without the need to create new institutional arrangements?
4. Name one organization of post-literacy education that has been introduced in your country as part of the developmental planning effort since independence. How is it doing? Has it become an "institution" as we have defined it above in this section?
5. What organizational problems are likely to arise as you engage in comprehensive planning of programs and curricula during the 1980s for your country?

### Readings and references

Book. Melvin G. Blase (Ed.), Institution Building: A Source  
USAID, Washington, D.C., 1973.

Amy G. Mann (Ed.), Institution Building: A Reader.  
Bloomington, In.: International Development Research  
Center, 1975.

#### 4. Needs analysis and community diagnosis

Literacy workers engaged in the design of programs and curricula for the post-literacy stages must fulfill felt needs of the communities, and yet, at the same time, and perhaps more importantly, must fashion new needs among their learners. The felt needs of the people must be determined through processes of needs assessments and community diagnosis. The agenda for the needs to be fashioned will have to be deduced from the national visions as projected by the nation's elite. The two must be brought together through a dialectical process described in Chapter 4, "Assessing Developmental Needs and Educational Needs of Communities" in Curriculum Development for Functional Literacy and Nonformal Education Programs by H. S. Bholá. (Refer to the monograph supplied as part of the workshop documentation.)

#### Things to do or think about

1. Have you ever personally engaged in a systematic needs assessment at the community level? Did you meet any surprises in regard to the "felt needs" as expressed by people or did all those needs turn out to be as you had anticipated?
2. In your present plans for post-literacy programs and curricula, which one's are based on the felt needs of the

people and which ones are indeed seeking to fashion new needs?

### Readings and references

Ralph W. Tyler, Basic Principles of Curriculum and Instruction. Chicago: The University of Chicago Press, 1949.

John D. McNeil, Curriculum: A Comprehensive Introduction, Boston, Mass.: Little, Brown and Co., 1977.

Irwin T. Sanders, The Community, New York: The Ronald Press Co, 1975.

### 5. Counselling and guidance for adult learners

Literacy workers are not merely in the business of teaching literacy skills or simply transferring information to adult learners on such subjects as agriculture, health and hygiene. They are indeed engaged in the processes that involve new socializations for most adult men and women participants.

Re-socializations involve basic personality changes "from a sense of inadequacy to a feeling of personal efficacy, from rigidity to flexibility, from narrowness to cognitive openness, from suspicion to trust, from ignorance to knowledge."<sup>1</sup> Such fundamental transformations require an interpersonal context defined by empathy, understanding, and trust which, in turn, points to the need for an effective

---

<sup>1</sup>Alex Inkeles and David H. Smith, Becoming Modern: Individual Change in Six Developing Countries. Cambridge, Mass.: Harvard University Press, 1974. (Page 10.)

support system of advice, counsel and guidance.

Counselling and guidance simply means the process whereby a counsellor helps a counsellee to verbalize his problems, identify factors that might be causing the problems, determining actions needed to solve those problems, and the strategies for taking actions, individually and in collaboration with those who might help.

We realize, of course, that counselling and guidance services are often unheard of even within the formal school settings in most Third World countries. Talking of counselling and guidance in the adult education setting may, therefore, seem much too idealistic. It may even be claimed that a good adult educator working at the community level is doing counselling and guidance all the time, without using the counselling label for his behavior. This is not a point that we want to argue at this time. Instead, we will simply suggest that as adult educators we must start thinking about the need for counsellor-consultant functions that can help adult men and women get through the crises involved in late socializations that are a part of the process of social change.

The challenges of counselling and guidance in the post-literacy stages will be:

a) to interpret program and curriculum objectives, designed nationally or regionally, to individual adults and youth; and to share with national and regional planners, the

aspirations of local communities as well as those local experiences that may seem to have national promise.

b) to assist adults and youth in breaking the connection between literacy acquisition and a salaried, non-manual job; and to help adults understand the tangible and intangible benefits of literacy as it begins to permeate their lives and work.

c) to help those who do want salaried jobs to evaluate their chances realistically; to understand the costs involved in jobs away from home; and to help them locate jobs and to compete for them.

d) to help those who want to continue their education independently, or by joining organized groups, to make proper choices from various available programs.

e) to assist adults and youth to put their literacy skills to work in social, political and economic aspects of their lives; to generate income and become entrepreneurs.

Enid Hutchinson has listed the necessary features of a counselling service for new literates in a city as follows:

1. Diagnostic skill in relation to the individual student's difficulties and abilities ...;
2. Knowledge of standards demanded by academic and training bodies ...;
3. Knowledge of the total educational system and, in particular, ... after-school education ...;
4. Knowledge of the educational and social system ...;

5. Insight into the motives driving the students ...;
6. Recognition of the difficulties, psychological, family and economic, encountered by most adult students;
7. Knowledge of employment or other opportunities likely to open to the students ...;
8. Continuous gathering of information ...;
9. Follow-up of students' subsequent careers and evaluation of the results of counselling .... (Page 37).<sup>1</sup>

While the clients of Hutchinson's program were city dwellers in a European city, the nine needs identified above should suggest what we might have to do in developing a counselling and guidance program for rural adults in developing countries.

#### Things to do or think about

1. Do you think that the counselling and guidance needs of adults and youth in your programs are being met to some degree of satisfaction even if the phrase counselling and guidance is never used?
2. Do your field workers have adequate skills to provide counselling to individual adults and young people in interpersonal settings; and do they have all the needed information to guide adults' decisions and choices?
3. What are the minimum conditions that must be met for

---

<sup>1</sup>Enid Hutchinson, "Counselling--Needs to Be Met," Adult Education (London), Vol. 42, No. 1, May 1969, p. 29-38. (EJ 004 335)



counselling and guidance functions to be adequately performed in your program setting?

### Readings and references

Diana J. Ironside and Dorene E. Jacobs, Trends in Counselling and Information Services for the Adult Learner. Toronto, Canada: The Ontario Institute for Studies in Education, 1977.

This book was commissioned by Unesco. Chapters include: the social context of adult education in the 1970s; the need for counselling and information services; some trends in counselling programs and practices; trends in information services; and some innovations in counselling and information delivery. The book also includes an annotated bibliography of 268 items, an excellent resource in itself.

#### 6. Program and curriculum design issues and skills

It is self-apparent that literacy workers planning programs and curricula for the post-literacy stages will need the skills of program development and curriculum development.

The process of curriculum development has been discussed in detail in an earlier monograph, Curriculum Development for Functional Literacy and Nonformal Education Programs by H. S. Bholra which should be reviewed by readers of this material. Special attention is invited to "The Analyzer" on pages 108-119 which describes in detail the process of generating curricula to fulfill particular

developmental needs of communities.

We have said elsewhere that while curriculum development means developing a "course of study"; a program design is, in essence, the process of developing a "course of action." At the post-literacy stages, program design takes the form of designing delivery systems and creating instructional-functional roles to implement those delivery systems. It is for this reason that we have paid special attention to organizational design and institution building in this monograph. (See Technical Appendices.)

There are some special issues in programming and curriculum development to which post-literacy workers may want to pay special attention. We have selected two for a brief discussion:

#### Reaching the specially disadvantaged

We are beginning to understand now that reaching the very poor and the specially disadvantaged is a most difficult task. Many of these disadvantaged groups have become "invisible" to us through long neglect, such as women, minority groups and ethnics in most countries, until recently. Even when these neglected groups have been pressed on our consciousness, we have often failed to go beyond stereotypes and have imposed on them what we thought was good for them.

There is yet another problem: the costs that the poor and the disadvantaged may have to pay for their very participation in the programs. We know now that those who

already have enough can get more, more easily; but those who have next to nothing, find it difficult to avail of what little is offered to them. Often they have been neglected as laggards. When reached, we do not understand the opportunity, costs they have to pay to avail of the services offered to them.

Working with women. Women have, of course, now been discovered almost everywhere in the world by development workers, but that does not mean that we have really learned to work with them.

We still keep on looking at women and their needs in stereotypical ways. We design programs based on what interests we think women should have, rather than on the interests they do have. Typically, we conceive of the women's future inside the home. When we do think of women's economic contributions, we lump all women's work under the so-called "informal sector" and even actively legislate to work the informal sector out of existence in favor of the so-called modern sector. We leave women to low salaries at low productivity, and give them no capital for investment, all because they are in the informal sector.

#### Participation and institutionalization

We have indicated often before, that an important part of programming in the post-literacy stages is the task of

designing delivery systems. In other words, we have to learn to design organizations and to build institutions. We have included a full Technical Appendix on the subject in this manual.

However, we have to ensure that institutionalization at the community level does not abolish local initiative; and that mobilization of community does not become regimentation.

It is a well-known fact that institutionalization and participation do not always go together; they are not naturally congenial and one has to work to make the two harmonize. Some sociologists recently have talked of the concept of mediating institutions to serve as buffers between the centralized bureaucracies of the State and the local, and often powerless, communities. Designing such mediating institutions will be a challenge that literacy workers planning programs in the post-literacy stages must meet.

Finally, we have to deal with the question of strategic choice of delivery systems for implementing programs in the post-literacy stages. While the availability of alternatives is generally a good thing to work toward, we must put available scarce resources into delivery mechanisms that avoid duplication and contribute to integrative planning and delivery of services.

Two popular mechanisms for delivery of post-literacy programs have been (a) the folk high school (and its different variations), and (b) the polyvalent center. Short notes on

these two institutional mechanisms have been included in the Technical Appendices. Also included in the Technical Appendices is a note on "Learning Resources Centers (LRC's)" which, we suggest, can serve as a parsimoneous institution: in the urban areas, the LRC will become a polyvalent center and in the rural areas it will become a folk high school.

Things to do or think about

1. Among the populations that you seek to serve, are there some groups that you will describe as severely disadvantaged? What kinds of programs and curricula have been or are in the process of being planned for such groups to serve their post-literacy needs?
2. How do you ensure that the women's point of view is represented in your program and curriculum design at various levels, from the national to the local?
3. Who are some women leaders of national stature in your country? Have they done an effective job of projecting women's needs to the policy makers? What has been their substantive contributions in terms of results obtained?
4. What opportunities are available for participation by local communities in the planning of programs and curricula in the post-literacy stages. Has there been an attempt to build government-people collaboration into the institutional mechanisms themselves? How?
5. Do you have centers, institutions or other mechanisms

which under different names serve the functions proposed to be served by the Learning Resources Centers (LRC's)?

6. Evaluate the concept of Polyvalent Centers and evaluate its possible contribution in your particular settings.

7. What has been the experience of your country with the folk high school idea? What is its future?

#### Readings and references

Irene Tinker and Michele Bo Bramsen (Eds.), Women and World Development. Overseas Development Council, New York, 1976.

Ester Boserup, Women's Role in Economic Development. New York: St. Martin's Press, 1970.

#### 7. Evaluation in the post-literacy stages

General problems of evaluating functional literacy programs have been discussed in a recent monograph, Evaluating Functional Literacy, by H. S. Bholá. This monograph has also discussed approaches and techniques for operationalizing evaluation within a functional literacy program, developing appropriate evaluation agendas, designing evaluation studies, writing and testing instruments of data collection and data analysis.

Special problems of curriculum evaluation were also discussed in a short chapter in another monograph by the author, namely, Curriculum Development for Functional Literacy and Nonformal Education Programs. In this section, we will define the focus further yet and present some introductory

notes on the problems and challenges of evaluation in the post-literacy stages. Acquaintance on the part of readers with the two monographs quoted above is assumed.

In this section, we will attempt, essentially, to do the following:

- a) Develop a set of typical evaluation needs in the post-literacy stages;
- b) Discuss some general approaches to the evaluation of programs and curricula in the post-literacy stages; and refer to some evaluation techniques of special relevance to conducting evaluation in the post-literacy stages.

#### Evaluation needs in the post-literacy stages

As indeed it has to be, evaluation needs in the post-literacy stages arise from the need for feedback. Feedback may be required at various levels of the program and on various parts of the program. To evaluate a total program for the post-literacy stages will be like evaluating the performance of drums and flutes and all other instruments; of the orchestra as a whole; of the conductor; of the music made; the acoustics of the hall; of the people who came to listen; and the society which allowed the emergence of such music, such halls, such consumption of culture by such a group of people.

Those planning and implementing post-literacy programs and curricula may thus want to know:

1. Whether they had hit upon the real needs of potential clients of the post-literacy programs within the framework of national agendas?
2. Whether they had developed the right programs (curricula and delivery systems) to meet those needs?
3. Whether the programs offered were effectively designed and the instructional materials were effectively produced?
4. Whether the right people were making use of the programs and curricula offered?
5. Whether the programs and curricula were having the right impact on the lives of the participants and on the society, in general?
6. Whether the programs had gone through a displacement of goals; or any unanticipated consequences on the lives of participants or the society had resulted?

#### General evaluation approaches and techniques

The basic overall objectives of programs and curricula in the post-literacy stages are to enable people; (a) to retain their literacy skills; (b) to learn more by reading, listening and viewing; and (c) to apply what they have learned in their daily lives. This means that citizens become independent learners and that they also become active participants in the transformation of their own milieu leading to the development of their societies.

The task will be most complex and, as we have indicated,



will involve a multiplicity of programs and projects, and perspectives of function and time. The evaluation of these tasks will be equally difficult. We can, for example, evaluate the immediate impact of each individual program on participants. But we may also want to study the delayed impact which will be much more difficult. Indirect and unanticipated consequences may often be beyond our resources and sometimes even beyond our understanding. We may, for instance, be unable to say much about how different programs act synergetically to change participants. We have not always been able to know what social linkages exist in a community and how those could be energized or complemented. Also cause-and-effect relationships between program participation, internalization of learning, acquisition of new self-concepts, and social and structural changes are not always easy to establish.

The tabulation below should give us an idea of the variety of evaluation needs in the post-literacy stages and how these evaluation needs might be studied:

<u>Evaluation Topic or Interest</u>	<u>Approaches or techniques</u>
Status of needs	Needs assessments
Number of literates, illiterates, and relapsed illiterates	Surveys
The expressed needs of new literate	

Program design evaluation	Peer review or expert review
Program utilization	
Utilization ratios	Surveys
Unit costs	Cost/effectiveness analyses
Impact on individuals	In-depth case studies
Aspirations	Interviews and content
Satisfactions	analysis of interviews
Modernity	
Use of skills for	Tracer studies
interventions in the	Secondary data analysis
milieu	
Role and institutional	Naturalistic studies
analysis	
Role design	
Role performance	Field studies
Institutional studies	Policy studies

Things to do or think about

1. What program or project of post-literacy stages has been systematically evaluated in your country programs? What were the results? How were the evaluation results obtained actually used in the ensuring planning process?

2. What, to your mind, is the most promising evaluation question in the area of post-literacy programs in your country that deserves to be studied urgently? How do you think should this particular evaluation question be studied?

3. It is often asserted that in the post-literacy stages (a) instructional materials and curricula are evaluated more often than the planning process and the delivery systems themselves; and (b) achievement of individual adults are studied more often than broad impacts on the lives of communities? Is this true? Is there an explanation for these conditions to prevail?

#### Readings and references

Unesco/UNDP, The Experimental World Literacy Programme: A Critical Assessment. Paris: The Unesco Press, 1976.

Includes, as the title suggests, a critical assessment of the Unesco/UNDP Experimental World Literacy Programme (1967-73) under which functional literacy projects were implemented in eleven different countries.

H. S. Bholá, Evaluating Functional Literacy. Amersham, U.K.: Hulton Educational Publications (in Cooperation with the International Institute for Adult Literacy Methods, Teharan, Iran), 1979.

Carol H. WEISS, Evaluating Action Programs: Readings in Social Action and Education. Boston: Allyn and Bacon Inc., 1972.

A book of readings on the theory, politics and methodology of the evaluation of educational and social programs

Eugene J. Webb and others, Unobstrusive Measures: Nonreactive Research in Social Sciences. Chicago: Rand McNally, 1966.

An excellent monograph on approaches to observations and measurement particularly suited to holistic and naturalistic methodologies of evaluation.

W. J. Filstead, Qualitative Methodology. Chicago: Markham, 1970.

Ole R. Holsti, Content Analysis for the Social Sciences and Humanities. Reading, Mass.: Addison-Wesley Publishing Co., 1969.

An introduction and guide to content analysis as an approach to documentary research and evaluation.

Budd L. Hall, "Participatory Research: An Approach for Change," Convergence (Journal of the International Council for Adult Education), Vol. VIII, No. 2, 1975.

Yusuf O. Kassam, Illiterate No More: The Voices of New Literates from Tanzania. Dar-Es-Salaam: Tanzania Publishing House, 1979.

A small 60-page booklet contains translated and slightly edited transcripts of conversations with eight new literates in Tanzania. It is a good example of how much a literacy worker could learn about program impact on the lives of people by merely listening to people.

#### 8. Training of personnel for planning and implementation of post-literacy programs

As we have indicated earlier, program and curriculum design is an activity undertaken collaboratively by a group of people working at various levels of the system who together constitute the planning sub-culture. For each to play his part effectively, different members of the program and curriculum planning culture need to be trained for their jobs.

The variety of manpower required for planning and conducting post-literacy programs is huge. First, of course, we need the planners who have the planning skills as well as the synoptic view of the needs and requirements of the area called post-literacy programs. Then we will need a whole array of trained manpower in the substantive fields such as for:

- .. Writing books for new literates
- .. Planning and publishing rural newspapers
- .. Organizing rural libraries
- .. Writing self-instructional materials for correspondence courses
- .. Producing radio broadcasts
- .. Monitoring radio and discussion forums
- .. Teaching film appreciation and thus be able to conduct film forums

Again, we need:

- .. Specialists in rural drama and other folk media to be able to conduct programs in that area
- .. Teachers of science and technology to be able to teach and explain intermediate technology
- .. People who can organize programs linking literacy with income generation, or literacy with political participation
- .. Health educators and family planning specialists who can integrate their materials with the teaching of literacy
- .. Animators

- .. Researchers and investigators who can conduct needs assessments and can argue for particular program initiatives
- .. Media specialists who can design non-projected visual aids and taped presentations
- .. Managers of Learning-Resource Centers and Polyvalent Centers
- .. Curriculum development specialists who can design curricula to order, to fit the ever-changing needs of various groups of people.

We have provided this list to give the planners of post-literacy programs a sense of the task that awaits us. We do not have to wait for the people to be trained before anything can be done. The work must begin. But we should improve the system as we move.

#### Some approaches to training

It is impossible to suggest specific training approaches for a training program which is as diverse as the one sketched above. The following general suggestions are made for local adaptation and possible use:

1. Policy makers will do well to devise a five (or even a ten) year training plan that anticipates training needs over the years and can plan for fulfilling those needs.
2. The training should be predominantly in-service training. Pre-service training of long durations should be avoided.
3. As far as possible, training should be located inside the country or in a neighboring country with similar socio-economic

settings. Unless there are clear and defensible reasons to send people abroad to America, Europe, or Asia training should be conducted in the home country.

4. Training should use local resource persons, if at all possible. One should not be looking for a team of UN researchers or broadcasters if such a team can be built from the local university or the national broadcasting service. Certainly, local talent must be used as part of faculty resources to conduct training even where outside resources must be used.

5. Training should be practical, providing opportunities to do something with what is learned. Good use should be made of understudies and internships. Due attention should be paid to the case study approach.

6. Since in many sectors, no standardized body of methods or procedures may have emerged, both "teachers" and "students" will be learning. Therefore, training should be participatively designed and participatively conducted. In other words, instructors and trainees should be able to exchange roles and must collaborate in planning and instruction at the training sessions.

7. Training should not be seen as a single-shot affair, but should be seen as a long-term opportunity for manpower development in a particular sector. There should be continuity and reinforcement.

Things to do or think about

1. What are your most urgent training needs in the area of program and curriculum planning in the post-literacy stages?
2. What specialized training institutions have been established in your country to fulfill the development training needs of your interest?
3. What kinds of training needs in regard to post-literacy manpower can be fulfilled within the formal setting of the university?
4. Have you participated in or read about the Unesco approach to Operational Seminars? What, to your mind, are the strong and weak points of this approach?
5. Are you aware of the workshop techniques for training and production utilized inside the Tanzanian EWLP, especially for primer writing and book production? What would you consider its advantages and disadvantages?
6. Evaluate the present workshop in terms of its training strategy. What do you think, particularly, of its approach of participative planning based on a negotiation of needs as seen by different individuals and interests attending the workshop?

Readings and references

S. Thiagarajan, Programmed Instruction for Literacy Workers, Amersham, U.K.: Hulton Educational Publications, 1976.

The NFE Exchange (Issue 14-1978/4). Institute for International Studies in Education, Michigan State University, East Lansing, Michigan.



Kamla Bhasin, Participatory Training for Development.  
(Available from The Office of the Coordinator, Freedom from  
Hunger Campaign, FAO, Rome), 1977.

## APPENDIX A

## POST-LITERACY ACTIVITIES IN TANZANIA

The following is a reproduction from an undated document picked up by the author in an international conference on literacy in 1978. It is included here to indicate how the Tanzanians define the scope of their "post-literacy programs" and to demonstrate the variety of programs that do exist in Tanzania.

## POST-LITERACY ACTIVITIES IN TANZANIA

Adult education and adult literacy form part of the main strategies for the national development goals. The national policy is that development should start from the rural areas since the majority of the population live there. By 1975, the national literacy campaign indicated that about 2.0 million adults had become literate. The projections are that this figure would have risen to over 4:0 million by 1980. These figures do not take into account those persons who had gone through the formal system of education but who for various reasons had relapsed into illiteracy. The rural population has no access to urban facilities, which, at any rate, are still limited in scope even to meet the demands of the urban populations.

The eradication of illiteracy requires methods and approaches to check the relapse into illiteracy, particularly of the new literates. The literacy and adult education as development factors are operating in an illiterate environment. Hence, the need to create a literate environment, and facilities for the provision of life-long functional education.

The following are the post-literacy activities, briefly described, that have been developed by the Project and the Ministry of National Education to provide a literate environment:

(1) Rural Libraries

Since 1969, the Project has been experimenting with and setting up rural libraries in the experimental Lake Zone districts. By 1974, 120 rural libraries had been set up. With UNESCO/NORAD assistance, the Project has now been able to establish 450 libraries, one for each Ward, in all the 18 districts of the four Lake Regions. (A ward is the lowest governmental administrative unit, with a population of 6-10 thousand persons.)

The ward library is expected to be stocked with about 1,000 volumes. It is run by a trained rural librarian on a voluntary basis. The rural librarian is provided with a bicycle and a book box or bag for circulating the books in the villages and literacy centres. In the villages and literacy centres the books are looked after by literacy centre supervisors and literacy teachers. Each library is expected to have a library discussion group.

The experience gained through the experiment in the Lake Regions has enabled the government to embark on an expansion programme by establishing rural libraries in each ward all over mainland Tanzania. These libraries are, however, still in the initial stages. The government intends to enable them to reach the sophisticated level as that obtaining in the four Lake Regions. The ultimate goal is to establish permanent libraries in all the villages in Tanzania.

(2) The Rural Radio Education Programme

The government has distributed over 6,000 radio sets, so far, on average 60 radio sets per district. There are 95 districts in Mainland Tanzania. The purpose of the programme is to establish a network of radio forums in the rural areas.

The radio education programme broadcasts include components for ordinary literacy classes and post-literacy groups as well as in-service training for literacy teachers and supervisors of adult education activities including rural librarians.

The scripts for this programme are fed back to the Materials and Book Production Department of the Literacy Project for the production of supplementary and follow-up reading materials to be used in the rural libraries. The scripts are also fed back for the production of the rural newspapers.

A unique feature of the radio education programme is the built-in feedback system for evaluation purposes and for future programme building. The feedback system enables the programmers to build programmes according to ~~the needs of~~ the target population. The issues, problems and questions raised by the target population, through the feedback system, form the basis upon which to write supplementary and follow-up reading materials for the rural libraries and in the production of the rural newspapers.

The Radio Education Programme, with its base at Literacy Project, Mwanza, has been in action since 1974.

Programmes for broadcasting:-

- (i) Kisomo kwa Redio (Learning by Radio) (twice a week)
- (ii) Mwalimu wa Walimu (Teacher of Teachers: for literacy teachers) (twice a week)
- (iii) Jiendeleze (For post literacy groups) (once a week)

(3) The Rural Newspaper Programme

Between 1969 and 1974, efforts were made by the Project to publish a monthly mimeographed rural newspaper for each of the four pilot areas. In 1974, with assistance from UNESCO/NORAD, a monthly printed rural newspaper was established. This covers the four Lake Regions: a single issue for all the four Regions. Forty-five thousand copies are printed monthly. All rural libraries post-literacy classes and literacy classes receive one copy of each issue, each month. The rest are sold at 10 cents per copy to the semi-literate and literate population in the villages.

The experience gained, after running the rural newspaper programme for three years in the Lake Regions, has motivated the government to plan for the expansion of the programme into five more zones. (Zones are administrative areas comprising of three or more Regions). The ultimate goal is that eventually there should be ward newspapers, that each household should be able to obtain a copy of the newspaper, fortnightly at least.

(4) The Rural Construction Programme

Rural Construction groups have been formed comprising of literates and semi-literates. These groups are intended as focal training centres for the villagers in carpentry, house building, tin-smithery, housecraft, etc. The aim of this programme is not to provide for future paid employment, but rather to provide knowledge and skills that will enable villagers to meet local needs. The development of small scale industries is being encouraged through this programme.

These groups have been established in each division all over mainland Tanzania. There are over 400 divisions in Tanzania.

(5) The Home Economics/Home Life Programme

As already seen under the list of literacy programmes, Home Economics forms part of the teaching programmes. Seen within the context of functional literacy concept, women programmes play an essential role in rural development. Women are encouraged to form groups in which they can learn, through practical skills, better home management. The Home Economics programme therefore, operating along similar conceptual lines as outlined under (4) above.

(6) Special Agricultural Oriented Projects

In order to enhance and to strengthen the implementation of functional literacy and functional education in the area of agriculture, it has been necessary to establish, in each division all over the country, agricultural oriented projects,

with a particular emphasis on training the villagers in modern agricultural practices according to the local environment and situations.

(7) The Production of Supplementary and Follow-Up Materials

In order to speed up the provision for suitable reading materials for the new literates and rural adults as well as development oriented materials, a central permanent Writers' Workshop, based at the Literacy Project, Mwanza, has been in existence since 1969. Similar workshops have been established in each region to cater for local needs. There are twenty regions in mainland Tanzania.

(8) Folk Development Colleges

The government has established 37 such colleges. The ultimate goal is to have one college in each of the 95 districts. It is expected that villagers selected by their communities will attend residential courses to acquire information, knowledge and skills for introduction, adoption and application on their return to their villages.

(9) Correspondence Education

Persons who have graduated from literacy classes, and others, are encouraged to pursue correspondence education provided by the Institute of Adult Education, Dar es Salaam.

(10) The Post-Literacy Programme

All the new literates are expected to participate in all the programmes mentioned so far (1-9), including the rural



libraries, wherever these are available in the local areas. However, it is believed that some of the individual new literates might not have access to some of these facilities. For example, not all the new literates will have access to the radio forums since the provided radio sets are still limited for the time being. Thus, an overall remedy has been to establish a "post-literacy groups programme" with a provided curriculum.

The mode of functioning of these groups is based on the concept of group discussion. The curriculum is flexible enough in such a way that individual groups will have to determine and decide on the type of learning.

## APPENDIX B

PRELIMINARY REPORT OF THE NATIONAL BOARD OF ADULT  
EDUCATION'S COMMITTEE ON POST-LITERACY AND  
FOLLOW-UP PROGRAMMES

The document that follows is an example of how India, in the midst of its massive literacy campaign that forms part of its more comprehensive National Adult Education Program (NAEP), is defining its problems of post-literacy; and what approaches and strategies it is planning to use to provide services to adults in the post-literacy stages.

Preliminary report of the National  
Board of Adult Education's Committee on  
Post-Literacy and Follow-up Programmes

149

(1) Appointment of the Committee and its meetings. On the advice of the National Board of Adult Education, the Union Education Minister appointed a Committee on Post-Literacy and Follow-Up Programmes under the Chairmanship of Shri J.P. Naik. The names of other members of the Committee are given in Annex 1. The Committee informally invited a number of other persons for discussions, a list of names of such persons is given in Annex 2. The Committee had three meetings, on 19.3.1979, 17.4.1979 and 30.5.1979. At the instance of the Committee an unstructured Seminar on Post-Literacy and Follow-Up Programmes in NASP was held in New Delhi on April 16-17, 1979. All the members of the Committee also participated in the Seminar.

(2) Decision regarding report. The Committee has been conscious of the rather limited experience in this sphere in India. Among the persons specially invited to participate in the meetings of the Committee were persons with significant experiences in this field, as well as persons who had observed such programmes in other countries, particularly in Tanzania, Thailand and Vietnam. The Committee has also been conscious that while there are a number of studies on matters connected with communication and retention of literacy, thorough studies having a direct bearing on the organisational aspects of post-literacy and follow-up programmes are lacking. The Committee has, therefore, requested the Director of the Directorate of Adult Education, Ministry of Education, to take up relevant studies. Meanwhile, the Committee has noted that in several parts of the country adult education programmes of about 10 months duration have concluded, or are soon to conclude. Therefore, it is essential that the State Governments and the various implementation agencies should have access to well-considered recommendations regarding the design and arrangements for post-literacy and follow-up programmes. The Committee, therefore, decided to make this interim report without waiting for the final report.

(3) The Approach. Neglect of post-literacy and follow-up programmes can be perilous. The past experiences in our country show that although awareness regarding the importance of such programmes was not lacking, they were seldom.

..2/-

systematically organised. This has been one of the most important reasons for the rather limited impact of the programmes taken up in the past. These programmes, therefore, should be given as much importance as the regular adult education activity itself. Since NAEF encompasses post-literacy and follow-up programmes also, the assumptions and objectives of NAEF must apply to these programmes as much as they do the regular 10 month programmes. Therefore, while programmes for reinforcement of literacy and numeracy skills shall have to be organised, equal importance should be given to programmes of functional development and of re-inforcing and concretising awareness built during the regular phase. It is also important that these programmes should be closely linked with the various schemes of socio-economic development. While it may not be proper to exclude any section which wishes to continue education, the emphasis should be on persons who have completed adult education courses or who have had education upto primary level. In the past the public library system has mainly served the comparatively well-off sections of society and this trend will have to be effectively countered. Besides, persons belonging to Scheduled Castes and Scheduled Tribes and Women suffer from handicaps in availing of post-literacy and follow-up services and special arrangements shall have to be made for them.

(4) Communication choices. The post-literacy and follow-up programmes in the past, rare though they were, had tended to get confined to post-literacy and public library type of activities. Although these activities would continue to be important, the various other means of communication must also be harnessed for creation of a dynamic learning environment. Therefore, in addition to the printed word, emphasis must also be laid on other available means like (i) traditional and folk forms of communication - such as puppetry, folk theatre, katha; (ii) sophisticated technological media - including radio, TV, films, slides; and (iii) group discussions and other means of group action - which may include sports and games, village planning, social service activities for improvement of the environment etc. The Committee feels the need to study the various aspects of these three communication choices in much greater detail than has been possible so far. Hence, without under-estimating the importance of these means

..3/-

of communication and learning, the present recommendations give some details mainly in regard to the use of the printed media.

(5) The printed media. It should be recognised that the printed word has the potentiality not only to assist in retention and use of literacy and numeracy, it can also become the medium for functional development and of awareness building. In connection with the printed media, the following specific suggestions are made:

- (a) In several cases it may not be possible for the learners to achieve self-reliance in literacy and numeracy during the regular programme. Provision should, therefore, be made for intermediate stage during which the learners would continue guided study.
- (b) Directorate of Adult Education and SRCs should be called upon to prepare lists of suitable materials for post-literacy programmes. Annotated bibliographies should be published by the Ministry of Education and the State Governments in various languages for use by the project agencies.
- (c) Various departments which publish extension material intended for use by non-literates should be asked to review their existing extension literature and to bring out material which is really suitable for the non-literates.
- (d) While it is necessary to provide appropriate incentives to writers and publishers to create relevant materials for this programme, emphasis should be laid on stimulation of creative energies in districts, cities, blocks and villages. Journals and wall-papers brought out for non-literates should also have local relevance.
- (e) Popular movements need to be generated for popularisation of science, for involvement of creative writers and for mobilisation of local effort for establishment of libraries. There is much to learn from Kerala in this behalf.
- (6) Guidelines. It is essential to provide guidelines for materials to be used for post-literacy and follow-up programmes. The principles

..4/-

enshrined in the Preamble of the Constitution should be treated as the basic guidelines regarding suitability of materials. In addition, areas of national concern might be identified, some of them being:

- (a) national and social integration while respecting diversity;
- (b) respect for all religions and fostering of the common cultural heritage;
- (c) democracy, freedom patriotism and self-reliance;
- (d) equality of opportunity and status, and freedom from exploitation;
- (e) inculcation of scientific temper and fight against blind belief and superstition;
- (f) protection of the rights of children, and observance of small family norm; and
- (g) environmental conservation and enrichment.

The National Board of Adult Education should lay down guidelines and a convention should be established so that all State Governments/UT Administrations also accept them. While it would not be advisable to prescribe or proscribe any materials, any activity, including printed materials, which militate against the guidelines should be discouraged.

(7) Organisational system. The objectives of NAEP would not be fulfilled unless learning environment is created and opportunities are provided for every individual to progress for optimum realisation of his potentiality. It would not be possible to proceed in this direction without involvement of the community in the programme from the very beginning, so that a time should soon come when properly organised groups in the community take over the responsibility for activities of continuing education and group action for community development. The Committee feels that attention also needs to be repeatedly drawn to the fact that unless conscious efforts are made to gear the delivery system for them women, persons belonging to Scheduled Castes and other weaker sections of

..5/-

community may continue to suffer from deprivations in this regard. Therefore, the responsibility for organisation of post-literacy and follow-up programmes should rest with the agency responsible for the regular adult education activities. All sizeable projects, say of 100 centres, should be provided for this purpose a post of Assistant Project Officer in the second year. In organisation of these activities, involvement of a number of other agencies would be necessary, including the local bodies, the development departments, the formal school system, the various technical and vocational training establishments etc. Students in secondary classes and in institutions of higher education could also substantially contribute to organisation of post-literacy and follow-up activities.

(8) Operational models and financial arrangements.

It would not be realistic to indicate a common system of post-literacy and follow-up programmes for all parts of the country. The Committee has, therefore, developed a variety of feasible operational models for organisation of post-literacy and follow-up programmes. It is necessary to emphasise that none of these models are intended to confine their activities only to reading and writing, but are envisaged as units for organisation of composite programmes. The Committee is conscious that the models it has developed are not entirely satisfactory and that it should be possible to improve these models on the basis of experience. It also recommends that the various implementation agencies should be enabled to design and try out other models also. Six possible models for organisation of post-literacy and follow-up programmes are attached as annex 3-8. In the models given at Annex 3, 4 & 5, a project of 100 AE centres is assumed - in Annex 3 & 4 there is further assumption that the 100 AE centres would be run in 65 villages. The courses described in model IV (Annex 6) should be organised in addition to the activities referred to in model I to III (Annex 3, 4 & 5).

.....

Model I Village Continuing Education CentreI. Cost at the Project Level

<u>Item</u>	<u>Recurring</u>	<u>Non-recurring</u>
(i) Pay of A.P.O. (CE) @ Rs.600/- P.M.	7,200	
(ii) Initial purchase of books (2000 @ Rs.2/- per book)		4,000
(iii) Replacement of books and purchase of periodicals	2,000	
(iv) Purchase of two almirahs		1,000
(v) Contingencies including TA of APO(CE)	2,800	
<b>Total:</b>	<u>12,000</u>	<u>5,000</u>

II. Cost at the village level

(i) Equipment (including trunk)		100
(ii) Books (100 @ Rs.2/- per book)		200
(iii) Payment to staff @ Rs.20/- P.M.	240	
(iv) Replacement of books and purchase of periodicals	200	
(v) Contingencies including kerosene oil etc.	160	
<b>Total:</b>	<u>600</u>	<u>300</u>
<b>Cost for 65 villages</b>	<u>39,000</u>	<u>19,500</u>

<b>III. Total cost of the project</b>	<u>51,200</u>	<u>24,500</u>
---------------------------------------	---------------	---------------



Model II Mobile library and continuing education unitsI. Cost at the Project level

<u>Item</u>	<u>Recurring</u>	<u>Non-recurring</u>
(i) Pay of A.P.O. (CE) @ Rs.600/- P.M.	7,200	
(ii) Initial purchase of books (2000 @ Rs.2/- per book)		4,000
(iii) Replacement of books and purchase of periodicals	2,000	
(iv) Purchase of two Almirahs		1,000
(v) Contingencies including T.A. of APO(CE)	2,800	
TOTAL:	<u>12,000</u>	<u>5,000</u>

II. Cost of the Mobile Units  
Cost per mobile Unit

(i) Purchase of one bicycle		450
(ii) Purchase of container carrier on cycle		50
(iii) Purchase of one almirah		500
(iv) Pay of Continuing Education Worker @ Rs.300/-P.M. (all inclusive)	3,600	
(v) Purchase of books (1000 @ Rs.2/- per book)		2,000
(vi) Replacement of books and purchase of periodicals	1,000	
(vii) Repair & Maintenance of bicycle	100	
(viii) Contingencies	300	
TOTAL	<u>5,000</u>	<u>3,000</u>

Cost of 7 Mobile Units	35,000	21,000
------------------------	--------	--------

III. Total cost of the project	47,200	26,000
--------------------------------	--------	--------

Model III      Continuing education at AE Centres

156

I. Cost at the Project Level

<u>Item /</u>	<u>Recurring</u> ( In Rupees )	<u>Non- recurring</u>
(i) Pay of A.P.O.(CE) @ Rs.600/-P.M.	7,200	
(ii) Initial purchase of books (2000 @ Rs.2/-per book)		4,000
(iii) Replacement of books and purchase of periodicals	2,000	
(iv) Purchase of two almirahs		1,000
(v) Contingencies including T.A. of A.P.O.(CE)	2,800	
	-----	-----
TOTAL:	12,000	5,000
	-----	-----

II. Cost at the AE Centre level

(i) Payment to staff @ Rs.10/- per month	120	
(ii) Purchase of trunk		50
(iii) Purchase of books (75 @ Rs.2/- per book)		150
(iv) Replacement of books & purchase of journals	100	
(v) Contingencies	100	
	-----	-----
TOTAL:	320	200
	-----	-----

Cost of 100 Centres: 32,000      20,000

III. Total cost of the project

44,000      25,000

Model IV      Need-based Continuing Education Courses

157

A. Course leading to Vth or VIIIth Class Certificate  
(10 month duration)Cost per course

(i) Payment to staff @ Rs.50/- per month	500
(ii) Teaching/learning material @ Rs.10/- per learner for 25 learners (assuming supply of free text books)	250
(iii) Teaching aids, charts etc.	250
TOTAL:	<u>1,000</u>

Cost of 5 courses 5,000B. Vocational/Environmental/Family  
Life Courses (Average duration  
30 days)

(i) Honorarium to trainer	200
(ii) Teaching/learning material and contingencies	100
TOTAL:	<u>300</u>

Cost of 10 courses 3,000Total cost of 5 courses of  
A Type and 10 Courses of B Type 8,000

Model V      Follow-up activities through students

158

Involvement of 50 N.S.S. students for 3 hours a week for 40 weeks. Each student to cover 12 families visiting each family twice a month.

<u>Item of expenditure</u>	<u>Recurring</u>	<u>Non-recurring</u>
1. Purchase of 1,000 books (@ Rs.2/- per book)		2,000
2. Replacement of books and purchase of periodicals etc.	2,000	
3. Purchase of two Almirahs for N.S.S. Headquarters		1,000
	-----	
TOTAL:	2,000	3,000
	-----	

168

Model VI Diversification of Existing Village Libraries  
 (assuming that funds for library services  
 already exist)

159

<u>Item</u>	<u>Cost (recurring)</u> (in Rupees)
(i) Organisation of 10 short duration functional training courses of one week duration on an average, @ Rs.100/- per course.	1,000
(ii) Sports & Recreational activities	500
	-----
TOTAL:	1,500
	-----

## APPENDIX C

# NO MORE SCHOOLS?

Seaview January 1980

**P**Primary schools throughout Sealand are closing! School bells no longer ring. On visits to three isolated villages during the past week this reporter did not see one class in session. In response to my questions about the cause of this calamity, I received tolerant smiles from villagers and was told time and again that "our concern is not with schools, it is with the education of our children."

What has happened in Sealand is a revolution in education. Seven years ago, budgets of these countries were strained simply to provide education for one-half of primary age children; today, even in remote villages, essentially all children are receiving primary education. The concept that has brought about this revolution is the one voiced in my recent visits to Sealand villages — "our concern is not with schools, it is with the education of our children." A totally new system of primary education has been based upon this concept, and it represents a dramatic departure from the familiar and traditional primary school classes of my own youth.

How did this new system come about? It started with the Southeast Asian Ministers of Education Organization (SEAMEO), a cooperative effort on the part of eight countries in Southeast Asia to pool their resources in an attempt to solve pressing educational problems common among the countries of the region. The organization, in planning for the future, documented its planning under

the title of "Educational Development Programmes for the 1970's", and a high priority was assigned to the development of an effective and economical delivery system for mass primary education. The 1970's have passed, and the "no school" education which I recently saw in Sealand villages is the outcome of SEAMEO's far-sighted planning for the 1970's.

## Mon Lia Goes to "No School"

Mon Lia is the 10-year old son of a farmer in a village of Sealand. In questioning him, his parents, the district education inspector and others in the village I was able to piece together the following picture of the educational revolution through the eyes of those who are taking part.

Q: Mon Lia, what grade are you in?

Mon Lia: I don't know.

Father: We don't have grades or classes any more. Mon Lia, tell him what modules you have completed.

Mon Lia: In Language I have completed module 23, in Science module 17, in Mathematics 15, in Social Studies 12, and in Applied Projects 28.

Q: I don't quite understand. What is a module?

Mon Lia: It is a learning unit that usually takes me about a week to finish.

Q: Is it a chapter in a textbook?

Mon Lia: No, I don't have any textbooks. A module can be lots of things. Most times it is a self-instructional booklet of about twenty pages that I can do by

myself. Of course, I do have to ask somebody to help me sometimes. Other times a module might ask me to work with a shopkeeper, or a carpenter or even the village headman. Once a bunch of us helped the district health officer on a project to drain water from some areas to get rid of mosquitos.

Why don't you use textbooks?

strict Inspector: We found that it would be a lot cheaper to have modules because we don't need so many. For example, once Mon Lia finishes a module he turns it in and somebody else can use it. Having a textbook is like carrying around twenty or thirty modules, even though a child can only read one chapter at a time. Mon Lia, let him see your Science Module 18.

(Science module 18, as I examined it, most certainly was not a textbook. In the first place, the pages were fairly thick — probably some kind of plastic. I was told that much money was saved because the plastic pages allowed the module to be reused many times without deterioration. It could even be cleaned up after being dropped in a puddle of water — boys will be boys in any country. The content of the module was in the national language and I couldn't read it, but it clearly was a lesson on the human heart, and it included a number of three-color pictures. There wasn't much of the usual textbook about it. Obviously, it was some form of programmed instruction with places for Mon Lia to answer and to check

- his own answers. Pretty sophisticated stuff for a ten-year old.)
- Q: Mon Lia, isn't a module like this difficult for you to do?
- Mon Lia: I have to work hard, but I know what to do and I can ask for help if I need to. I had to learn to read first and then I had to "learn how to learn", that is, I had to learn how to use each module.
- Father: I never went to school, but I know what Mon Lia should be doing at any time. Even though I don't always know what it is he is learning, I know the steps he is supposed to follow. All the parents in this village, thus, can help their children on how to learn. We also can keep track of what they are doing and, because they are our own children, we are responsible for their progress. Mon Lia also is responsible because we both know that both he and our country will benefit from his learning.
- Q: Mon Lia, you said that you have "learned how to learn." What do you mean?
- Mon Lia: Every time I pick up a new module, I listen to a cassette tape while previewing the module. I can listen to it as many times as I want until I am sure of what to do.
- Q: Aren't cassette tapes expensive?
- District Inspector: There are two inexpensive cassette players in the village and each module has only one cassette. The two players are necessary in case one breaks down and has to be repaired. They are a lot cheaper than a teacher.
- Q: Mon Lia, you also said that you had to learn to read first. How did you do that? You couldn't have learned from a module like this one on the human heart.
- Mon Lia: Even before learning to read, I had to learn to speak.
- Q: I don't quite understand.
- Mon Lia: Most of the kids here grow up speaking a different dialect. We only know a few words of the national language when we start primary education.
- Q: How did you learn to speak?
- Mon Lia: When I was about six years old, I started listening to some radio programmes which taught children how to understand the national language.
- Father: We have four or five transistor radios in the village. Much of the time they are used by younger children in learning national language. There are also adult

- programmes which we listen to. I have made several changes on the farm after listening to agriculture programmes.
- Q: Mon Lia, so you learned to speak only by listening to the radio?
- Mon Lia: No, but the radio helped me get started. Some 8 to 10 of us had a class in the main house of the village where we listened to special cassette tapes. Some of the kids' parents who spoke our dialect also helped us out.
- Q: Did you have a teacher?
- Mon Lia: Not really. The same parents helped out; some of the older kids also helped us.
- Q: Then you learned to read?
- Mon Lia: Yes, but we had to pass a listening test first to make sure that we knew enough to learn to read.
- Q: Who gave the test?
- Mon Lia: The Instructional Supervisor was here one day and gave it. Sometimes parents or older kids give it.
- District Inspector: The Instructional Supervisor (IS) is the professional who manages the whole primary system here. The IS for this village also is responsible for two other villages in the district and makes regular rounds of the villages.
- Q: I would like to find out more about the IS. But first, Mon Lia, what happens if you don't pass the listening test?
- Mon Lia: They find out what we do and don't know, and parents and older kids coach us.
- Q: How long did it take you to learn to speak and understand the national language?
- Mon Lia: About four months; it was fairly easy. Some kids take one or two years because they weren't able to learn it full time; they had to help their fathers.
- Q: OK, once you learned to speak, how did you learn to read?
- Mon Lia: By programmed teaching and by modules which I could take home.
- Q: What is programmed teaching? Is it a special method that your teacher uses?
- Mon Lia: The person who taught you wasn't really a teacher; it was a parent who had graduated from primary school and could read.
- Q: Not a teacher?
- District Inspector: Mon Lia is right. The people who act as teachers here are not graduates of a TTC, and they only have a primary educa-

- tion. In this village, for example, three members of the community have volunteered to work part-time in the programmed teaching programme for reading. They are paid by the hour at a rate of about one-third of what it would cost for a teacher who had graduated from the TTC. We give them two weeks of specialized training in very specific techniques for teaching reading. Two older children who are in approximately their last year of primary education also have become programmed teachers. All older children are required to spend time in helping younger ones learn different subjects, quite often by individual tutoring. This scheme has been very successful. Not only do the younger children learn quite effectively, but the older students also report that they themselves have learned a lot by teaching others. Because these villages have very little money, the free time given by older students in the teaching of the younger ones represents real savings. Before we had the new system, any teaching had to be done by a qualified teacher who was paid a regular salary, and there was no way that this village could afford to pay a full-time teacher. In several places in my district military servicemen fulfill some of the teaching aide functions.
- Q: During all the time that we have been talking today, I have yet to find out what the school teachers do.
- Mon Lia: We don't have any -- just some of the parents and older kids.
- District Inspector: Mon Lia is right. Under the new system we don't have teachers and classes and textbooks in the same way that we used to. We simply cannot afford it.
- Q: But I have seen some fairly sophisticated instructional materials -- learning modules, transistor radios and cassette recorders. How can you afford these things?
- District Inspector: For the simple reason that we do not have teachers. Traditionally, more than 80 per cent of education costs have been teacher costs -- salaries, retirement, training, etc. The most revolutionary change made by the SEAMFO primary education system was to eliminate the use of professional teachers who were tied to the classroom and to retrain

them to become Instructional Supervisors. The usual student-teacher ratio in the past was 3:1. Our present student-Instructional Supervisor ratio is 200:1. The IS's make a much better salary than they did as teachers, but we still have realized at least a four-fold savings in teacher costs. The money we have saved in this way is used for instructional materials of various kinds and to pay modest stipends to local instructional aides (community members with special skills).

One other benefit of this new scheme has been our ability to retain good IS's in the rural communities. We had a very difficult time in the past in attracting and keeping good teachers in the villages. The increased responsibility, prestige and income of IS's seems to have played a big part in making rural education more attractive to top people.

Q: I now have a fairly clear idea of the kinds of learning experiences which children such as Mon Lia have under the new system. I also understand to some extent how the community draws upon its own resources to assist in primary education. But I am not clear exactly what part the Instructional Supervisor plays in all this.

District Inspector: Throughout my district, each IS has the responsibility for about 200 primary children. In some of the larger towns there are two or three IS's. For small villages such as this one, however, there is only one and he is responsible for two other villages as well.

In larger towns, an IS will have an office in a permanent learning centre. Here, however, the learning centre is mobile. The IS travels in a small van which is his mobile learning centre.

The learning centre is the hub of the primary education system. It contains the appropriate learning modules, the cassette instructions for each module, tests for each module, instructional materials for use by programmed teachers and by other kinds of teaching aides, and progress records of each student.

Q: Mon Lia earlier mentioned that he had to take a test on the national language before he could begin to learn to read. Does each module have such a test?

District Inspector: Yes, each module has several kinds of tests. First, when a child selects a new module he takes a readiness test to insure that he has all the necessary prerequisites to benefit from the module. The results of a readiness test may, at times, indicate that a child needs to take another module first - or it may indicate that he should complete a review module, especially if he hasn't been able to take any modules for a long time because of illness or work on the farm. Most modules of the self-instructional types also have quite a bit of built-in self evaluation to help a child monitor his own progress and be ready for the post-test when he finishes the module. Successful completion of the post-test itself indicates that a student has achieved the objective of the module and his achievement is entered on his record, one copy of which is kept by the Instructional Supervisor and the other copy is kept by the student so that he can keep track of his own progress.

The system is very flexible since it allows a student to take a post-test even if he hasn't studied the module - if he feels confident that he can achieve the objectives of the module.

Q: What about adults, can they take the post-tests?

District Inspector: Of course, anyone in this village can take any of the modules or any of the tests. Primary education is no respecter of age. We used to worry about the dropout and wastage problems a lot more than we do now, and one reason for that worry was that if a child didn't finish primary school by the time he was about 14 years old we felt that the education system had failed. We even designed non-formal systems to upgrade the competencies of "over age" persons and non-formal education was kept fairly separate from primary school. What SFAMEO has done in this new system is to incorporate much of what was called either "non-formal" or "community" education into a single system of achieving the educational objectives of primary education.

A person can progress through primary education at his own pace. A number of children now start

school at a later age. (We have found that students who begin at an older age actually progress faster - providing some additional savings in our educational resources.) Many students are working, usually on their parents' farms. At certain periods during the year they do not have time to keep up their studies. However, they usually don't drop out as they used to when they would have been forced to repeat a grade on returning to school. Now they can come back and pick up where they left off, perhaps starting out with a review module to cover previous work.

Q: What form are the tests in?

District Supervisor: There are all kinds, depending on the objectives of the module. Sometimes there are performance tests on some practical skill, quite often there are knowledge questions, but the most usual form concerns the application of what has been learned.

Q: Does the Instructional Supervisor give all these tests?

District Supervisor: It is not possible. On the average some 100 students complete a module each week, perhaps 30 in each village. It takes about 15 hours each week in each village for testing alone. Volunteer aides give the tests. They have been trained by the supervisor to do so.

Q: Isn't there a chance for aides to score a child a little more favorably than he really deserves because of village pride?

District Inspector: We suspect that when we first started and people didn't fully understand the system, some favoritism was shown. But villagers soon learned that the tests were for a student's own good - to show his strengths and weaknesses as a basis for improvement. Since most persons now finish primary education there is no particular need for any examinations other than the tests associated with the modules. After all, the amount of education a child receives is up to himself and his family and they have come to realize that what they are learning is relevant to their lives as community members and as productive members of society. Children who desire to go on to higher levels of education must pass readiness tests before going on. These examinations are conducted periodically by the central government.



Q: We have been talking all afternoon about modules, but I have no idea how many modules constitute primary education.

District Inspector: The number varies in each subject, but the average number is about fifty.

Q: Getting back to the Instructional Supervisor — it appears that he is more a manager than a teacher.

District Inspector: That's very close to the truth. Let me list some of the duties of the IS:

... select and train teaching aides from the community in specific duties.

... assign tutorial responsibilities to older students and train them in these functions.

... conduct PTA meetings to orient and train parents for the self-management of their children's studies.

... survey community resources and enlist persons with specific skills to assist students to "learn by doing" for some of the applied modules.

... monitor all instructional and evaluation activities.

... maintain student records of progress, giving particular attention to those who are progressing unusually slowly as a basis for counseling with students and

parents.

... maintain a complete inventory of the learning centre, including instructional modules, equipment and tests, repairing or replacing as needed.

... provide feedback to the central government on the assets and liabilities of given instructional modules as a basis for improvement.

... serve as an advisor to the communities on educational matters.

Q: I'm still confused. It was a lot more understandable when there was the school, the teacher and textbooks. It seems that everybody in the village is somehow involved with the new system.

Father: That's about right. Students are helping students, parents are helping their children and specialists in the community are acting as part time aides. We couldn't do this on our own, though. We need the structure that is provided by the learning modules, and we need the organization, management and counsel of the Instructional Supervisor.

Q: I can guess your answer to this last question: How is the system working?

Father: If you mean if there are

problems, the answer is yes. There is often some kind of mixup, but it is getting sorted out fairly well.

If you mean if children are getting a primary education, the answer is a definite yes. No matter how fast they are progressing, there has yet to be a student in this village who has given up and stopped.

If you mean if children are in school, the answer is no. This is a "no school" village. **OUR CONCERN IS NOT WITH SCHOOLS IT IS WITH THE EDUCATION OF OUR CHILDREN!**

Note: There is very little chance that reporter will ever write the above article because many of the ideas presented are a bit fanciful; we do not know how feasible they may be. The INNOTECH research programme is being geared to conduct a series of long-term studies in an effort to develop a prototype system which can provide the region with an economic means for the delivery of primary education.

Although the news reporter of 1980 probably will not see a primary education system as described above it is INNOTECH's firm hope that when he visits a rural village, he will see a new and workable delivery system based upon the joint efforts of this Centre and the SEAMEO countries.

## APPENDIX D

SOME INTRODUCTORY LESSONS ON 'ORGANIZATIONAL LITERACY'  
FOR FUNCTIONAL LITERACY WORKERS

As we have suggested repeatedly in the text, programming and curriculum development in the post-literacy stages will require that post-literacy program planners design and install appropriate systems of action. That will mean the establishment of organizations and institutional arrangements that can provide services to new literate adults on a continuous and systematic basis.

It is, therefore, of utmost importance that post-literacy planners understand organizational behavior and the complex processes of institution building. The document that follows is but an introduction to the subject. As planners of literacy programs at the post-literacy stages, we will have to develop much more sophisticated skills in these twin of organizational design and institution building.



Prepared for  
an  
International Seminar

"The Design of Educational Programmes  
for the Social and Economic Promotion of Rural Women"

SOME INTRODUCTORY LESSONS ON 'ORGANIZATIONAL LITERACY'  
FOR FUNCTIONAL LITERACY WORKERS

by

H. S. Bhola  
Professor, Indiana University

SPONSORS:

THE WOMEN'S ORGANIZATION OF IRAN

THE INTERNATIONAL INSTITUTE FOR  
ADULT LITERACY METHODS



SOME INTRODUCTORY LESSONS ON 'ORGANIZATIONAL LITERACY'  
FOR FUNCTIONAL LITERACY WORKERS

by

H. S. Bhola

The Women's Organization of Iran (WOI) has the mandate to work for the social and economic promotion of rural women of Iran. This mandate the WOI has translated into the program mould of functional literacy. The choice of both the means and the ends is supportable. It is time to get the other half of humankind to join the march into the future; and to assist these women, both rural and urban, with the skills needed to function within the new partnership. Functional literacy, broadly conceived, can indeed be the means of actualization of our hopes for the International Women's Year.

Much would need to be done to translate hopes into concrete actions. One of the things to do would be, of course, to organize for social action on behalf of women. Whatever needs to be done systematically, and with continuity, needs a system - an organization of some kind. To bring the farmer the new technology of food production, to bring to the rural women new social visions and new economic possibilities, and to provide them with the knowledge and support needed to actualize these possibilities, systems of action

- 1 This paper has been written at a descriptive level. Its theoretical antecedents will be found in three papers by the author listed below: i) H. S. Bhola, "The Configurational Theory of Innovation Diffusion," Indian Education Review, Vol. 2, No. 1, January 1967, Pages 42-72. Available from ERIC Document Reproduction Service, P.O. Drawer O, Bethesda, Maryland 20014, under order no. ED 011 147; ii) H. S. Bhola, "Notes Toward a Theory: Cultural Action as Elite Initiatives in Affiliation/Exclusion," Viewpoints (Bulletin of the School of Education, Indiana University), Vol. 48, No. 3, May 1972, Pages 1-37; and iii) H. S. Bhola, "The Design of (Educational) Policy: Directing and Harnessing Social Power for Social Outcomes," a paper presented to the Indiana University

will have to be created. Clearly, most significant planned change today has to be organizationally-mediated.

One can argue that even though planned change is organizationally-mediated, we need not pretend as if organizations were novel to human experience. All cultures have had experience with organizations - some for centuries, some for thousands of years. As individuals, some of us have been governing organizations and most of us have been working within them. Why then, some introductory lessons in organizational literacy? The answer is that the fish are not necessarily the best experts on water; that while we do indeed know organizations experientially and intuitively, we do not know them systematically to use them effectively for social ends. In fact, most of us make less than an optimal use of organizations. We let them become barriers to, rather than, vehicles for social change. We let organizations tyrannize over us while we fight the symptoms rather than the real causes of our discontent.

The problems of organization and mobilization for literacy work can be separated in two parts. The first part is that of organizational design. The organization must be designed and then built with the expectation that it will perform the activities assigned to it. The second part is what is often referred to as institution building. Institution building is basically a description for the process involving the launching of an organization into social space, pretty much as a satellite is first fabricated and then launched into physical space. Whether we are engaged in organizational design or in institution building, we are dealing with systems and system design. Organizational design is system design because an organization is a formal social system. Again, institution building is

Educational Policy Conference held in Bloomington, Indiana, during November 21-23, 1974. A report of the proceedings of the Conference, to include eight papers, will be available as a special issue of Viewpoints to be published in May 1975. Copies of the various issues of Viewpoints may be ordered from the Publications Office, Room 109, School of Education, Indiana University, Bloomington, Indiana 47401. A limited number of copies of the three papers listed here are available from the author on request.

system design because a system (an organization) is being launched into a larger system (the society). The design problem now consists in helping the newly launched organization to come to terms with existing institutions and organizational networks (systems of various sizes and overlapping boundaries) and to relate with client groups and communities (a multiplicity of informal social systems).

In organizing our discussion of organizational design and institution building we would use the same conceptualization as in "The Configurational Theory of Innovation Diffusion."<sup>2</sup> It suggests that to describe, analyse, understand or to intervene within systems, systems may be ordered in terms of four variables: configurations and configurational relationships constituting the system, linkages within and between configurations within the system, environment surrounding the system, and resources being processed through the system under study. These four terms can be translated to fit the processes of organizational design and institution building as follows:

Configurational Theory Variables	Restatement of variables in terms of Organizational Design Processes	Restatement of variables in terms of Institution Building Processes
Configurations	Roles Units Sections Divisions Task Forces Teams	Organizations Associations Communities
Linkages	Rules Codes Informal communications	Co-ordination Animation Mobilization
Environment Resources	Organizational climate Resource management	Social climate Resource mobilization

<sup>2</sup> H. S. Bhol'a, "The Configurational Theory of Innovation Diffusion," Indian Educational Review, Vol. 2, No.1, January 1967, pages 42-72. (ERIC No. ED 011 147).

Two important points should be made here.

While these two processes of organizational design and institution building must be treated separately for simplification, in actual practice considerations about institution building (about a future organizational launch into social space) must determine, at least, some aspects of the initial design of the organization.

Second, when an organization is off the drawing board and is actually brought into being, it becomes a "living system". An informal organization grows within and upon the formal organization. This informal organization can never be completely anticipated and, consequently, can never be fully planned for. However, some typical aspects of living systems, that is, of the social architecture of organizations, have become known through research and these can be taken into consideration as part of the organizational design.

One must, thus, think in terms of accommodating two overlapping systems within organizational design:

- 1) The technical system, and
- social system.

#### ORGANIZATIONAL DESIGN

Organization is needed when something needs to be done systematically and with continuity and when the task to be performed is beyond the capacity of a mere individual. Organization is cooperation, a way of multiplying individual capacities to generate collective power. Cooperation leads to division of work which leads to specialized roles. This, in turn, creates the need for coordination of the work of specialists. In terms of our model, an organization may be seen as a set of roles, with rules for relating those roles in a functioning community, using resources, to fulfil its obligations to the social environment which gave it birth.

The organizational design problem then can be seen to include the following processes:

1. A valid institutional analysis should be primary. That would mean a confidence in the goodness of the institutional solution. Organizational designers must be convinced that the initiatives for development and change do require institutional solutions, and that the particular organization they are designing is part of the solution. For example, literacy cannot bring development in areas where needs are for agricultural extension and rural credit. Nor can literacy bring social cohesion to a community torn from racial or communal strife. The developmental problem must be amenable to institutional solutions, and literacy institutions must be part of these solutions for literacy organizations to have any meaningful goals.

2. Roles must be invented that can undertake the activities that policy goals of the institution require.

3. Rules must be invented that relate these roles into a purposeful collectivity, a power field that can do societal work.

4. Resources need to be created, and assured on a continuous basis, to be deployed both a) to feed and house the role incumbents within the organization, and b) to provide services to client groups in fulfilment of the obligations to the society.

These tasks are by no means simple. In the following we would deal with problems of role design, rule making, resource management and definition of organizational purposes. Both the logical and sociological aspects of these problems will be dealt with. We begin with a discussion of organizational goals and purposes.

#### THE DYNAMICS OF ORGANIZATIONAL GOALS AND PURPOSES

Obligation to the environment is part of our definition of an organization. It is indeed absurd to think of a purposeless organization but the relationship between ends and means within organizations is not always clear and direct. Organizations have manifest goals but they also have latent goals. Over time, initial organizational goals may get displaced. Goal displacement is the process by which organizations (as well as



individuals and groups) lose sight of their original goals and have them displaced by goals that are different, and even antithetical to their original purposes.

#### THE LOGIC OF INSTITUTIONAL PRESCRIPTIONS

As we have indicated elsewhere, organizations are created to make policy implementation possible. But human beings cannot always make the right social diagnoses nor can they always make the right social prescriptions. Creating institutions may not, in some cases, be part of the solution and sometimes the wrong institution may be created.

It can also happen that institutions are created not to fulfil specific policy directions but to carry forward general policy themes, such as, preparing the weaker sections in the society to participate in socioeconomic life of the country or to develop communities for life in a classless and just society. Not only does it become difficult for an organizer, in such cases, to logically translate policy into plans and programs of action, but such generalized themes overlap with the mandates given to other institutions in the society. This creates conflicts with existing institutions that claim the same jurisdiction. The need to co-ordinate and integrate work between different institutions thus becomes of utmost importance. The functional literacy programs would face special problems in this regard because of the very comprehensive socioeconomic and educational goals.

#### SOCIOLOGICAL CONFOUNDING OF ORGANIZATIONAL GOALS

Problems with regard to defining and understanding organizational purposes are not all logical; they also get sociologically confounded.

Organizations may merely serve symbolic uses and may be completely unable to fulfil the ostensible purposes assigned to them. Creation of a National Board of Literacy or a Committee on Total Eradication of Illiteracy may serve such symbolic functions.

Organizations may have latent functions different from those manifestly

stated. A church project may be interested in literacy because it provides a setting and stage for continuous contact for evangelism and proselytization in a developing area. A group of people may develop a literacy program not because of their interest in literacy but as a way of building a political base for themselves in the region. A literacy program may also be created by a government simply to give a false sense of movement - not to provide development but to practice what has been characterized as gradualism. Gradualism is a word used to denote political strategies whereby, instead of meeting the social and political aspirations of the people honestly and forthrightly, they are put on a slow calendar of gradual progress. Instead of passing egalitarian economic legislation to benefit an underprivileged community, they may be given more seats in elementary and secondary schools. Such gradualism is not uncommon.

Finally, organizations over time may go through goal displacement without realizing the drift in their purposes. An organization, set up to promote traditional media nationally, may become a local production center putting up folklore shows every evening. A national institute of audio visual education for a country may become an agency that produces graphic materials for the ministries of the federal government. A literacy institution set up to serve the local people may lose all touch with the communities, and may become a lobby for greater adult education budgets at state and federal levels. Or it may become a publisher and bookseller of books for new literates.

#### WHAT CAN A LITERACY ORGANIZER DO?

Literacy organizers cannot play God. They cannot control everything. They cannot insist on clarities of goals and specificity of policy directions by presidents and ministers of state, and on certainties of actions and consequences in an uncertain world.

Yet understanding is a prerequisite for doing the possible. By understanding the relationship between policy and organization, and by understanding the dynamics of systems of action one can do some things whatever the level of one's responsibility within a literacy organization. One can raise

questions; one can often force others to raise the same questions; one can raise doubts; one can question individual purposes, both his own and of others; and one can see if one should stay and help or leave for the good of himself and the organization. And if one stays, one can work on programs with a sense of commitment. Commitment to the organization's programs then can be spread all across the organization. This would mean, that all those working within the organization will understand the obligations due to the society that supports the organization. That is important.

#### INVENTING ROLES FOR ORGANIZATIONS

While some role theorists would draw subtle distinctions between positions and roles, for our purposes these two words could be used interchangeably.

Some roles were invented in our cultures and societies so long ago that they have become conventional roles. Everybody knows what the incumbents of those roles do and how they behave. There has grown around these roles sets of mutual expectations that are almost universal. Policeman, postman, teacher, soldier are some such roles. They come ready-made.

However, different organizations and different cultures have to create adaptations of the stereotypical roles we just mentioned. Functional literacy workers especially have to invent roles afresh since they are often dealing with different sociocultural realities and different pools of personnel resources. The conceptual background of their actions differ also from one project to another.

#### THE LOGICAL IN THE PROCESS OF ROLE INVENTION

A role invention job typically must start with objectives to be fulfilled by a program or a project. It must then be determined as to what tasks or activities must be performed to fulfil those objectives. Next it must be ascertained as to what tasks seem to go together and could be performed as part of single roles by one or more role incumbents. (See the schema on the next page.)

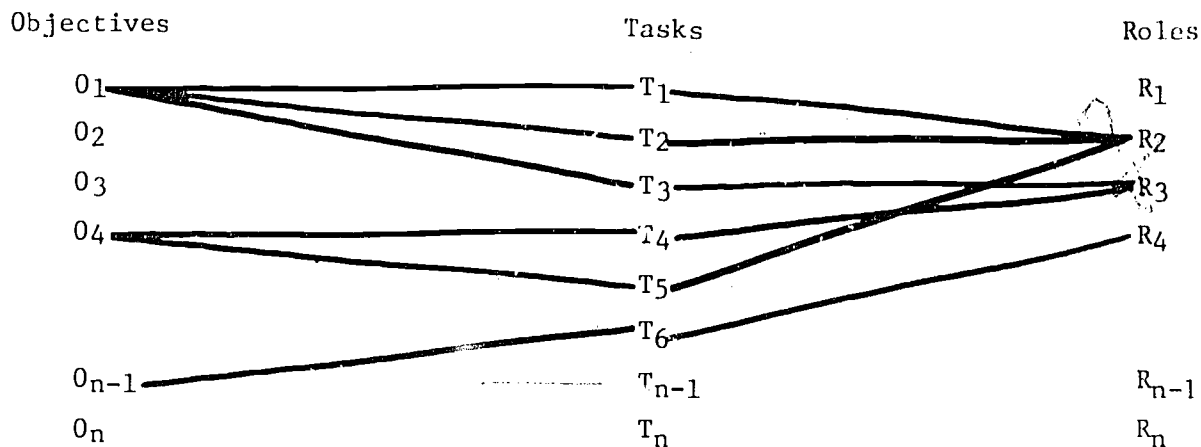

Figure 1. The process of role invention in idealized form.

The process is rational but difficult and often full of problems.

For example:

1. It is not so easy to state program objectives clearly. Organizations often fulfil latent objectives that they do not want to make manifest. They want such objectives to remain hidden.
  - 1.1. At other times all the organizational objectives are not anticipated; it is impossible to know the future. By definition future is unknown.
  - 1.2. Again, objectives may be added to the organization's agenda for political reasons requiring crude adjustments in role definitions.
  - 1.3. Even where objectives have been tentatively agreed upon, different administrators may assign them different values, or may underplay some objectives when translating them into activities and roles.
2. Translation of objectives into activities and tasks, again, is not as easy as it might seem. This is indeed a theoretical, rather than a rational, process. Different theories may provide different answers as to what activities and tasks should be performed to bring self-reliance among communities. What tasks should be performed to bring about group cohesiveness, communal harmony, community motivation and action? Even at a less abstract level, what tasks should be performed to make a community literate? To bring women to participate in the life of the community? To ensure that those who become literate actually use literacy in their daily lives to make it possible that literacy generates development?
3. Coalescing tasks or activities into roles is not easy or self-evident either.

Experience imaginatively treated will tell us what tasks might go together and what might not. For example, teaching of reading and writing and arithmetic may go together but not, necessarily, teaching literacy and agriculture. Driver and projectionist roles may be combined but not the driver and the cook. (In a Paris hotel, though, I saw the driver, travel guide, cook and bearer roles combined in one man!) Again, the pool of manpower from which the role incumbents will be recruited may create constraints or freedoms in role invention. In one particular society, it may be possible to combine the teacher, the group discussion leader, and the projectionist roles in one. In another, it may be possible to combine the driver and the projectionist. In one, the teacher may also teach agriculture; in another the agricultural extension worker may teach literacy; in yet another a team teaching approach may be feasible. In some societies it may be possible to put well-qualified literacy teachers in each adult group; in another the monitor concept may have to be invented. This would make it necessary to package most of the instruction through processes of instructional development so that the monitor roles can be usefully performed.

#### THE SOCIOLOGICAL ASPECTS OF ROLE INVENTION AND DESIGN

Once roles have been invented, role performers must be found. This presents a set of problems of a very complex nature.

1. In recruitment of role incumbents: a) we may misjudge people and get the wrong kind of workers; b) we may deliberately recruit people we know and recruitment may become a patronage system, especially so in economies of scarcities; and c) workers may be foisted on us because they have the right connections in the right places.
2. Once role incumbents are on board, we may find that they are not merely role performers, they are persons. We may find to our chagrin that these role performers have brought with them the excess baggage of their personalities! We hired only a part but we got the whole individual, with his social status, his political connections, his habits, temper and future objectives.
3. We may find that role performers, perform different tasks within the role, selectively, or invent a completely different role for themselves. They may do what they had been doing before in another organizational setting; may do what they know how to do, not what is required of them; may consider

that their sitting at the desk is work, irrespective of whether it has anything to do with the objectives of the organization.

4. There may also occur genuine role conflict. It is impossible for a supervisor to be both a teacher and an administrator. Most people like to rule rather than promote growth in other individuals. When a person is expected to play both of these roles, he neglects one to play the other.

5. While units and sections and task forces may be logically developed within an organization unplanned, overlapping informal groups emerge at the same time. These emerge because some people have similar backgrounds, similar interests, share their fears and their sources of power. There is nothing inherently wrong about the emergence of informal groups within organizations. In good organizational climates, informal groups play a highly positive role. In organizations with bad organizational climates, however, informal groups can become rumour mills and increase the dysfunctionality of the organization.

#### WHAT CAN A LITERACY ORGANIZER DO?

Essentially, these are the possibilities:

1. The first thing to do here, again, is to develop understandings. A literacy organizer must understand the dynamics of role design, mutual role expectations, role performance and interactions between role incumbents.
2. A literacy organizer must be careful not to borrow ready-made roles from other literacy organizations, in other places. He must design roles for his organization afresh to suit his purposes. The roles designed by him must be appropriate to the conceptual structure of his literacy program. They must also be appropriate to the realities of the society in which those roles will be performed.
3. The literacy organizer must be careful about the recruitment of individuals in the organization. He must not sabotage his own plans by recruiting friends, relatives, students, or admirers when they are clearly unprepared for the jobs to be done. He must also handle his politics in a way that powerful politicians or bureaucrats do not take away all initiative from him and fill his organization with their men, and thus doom the organization to failure from the very beginning.

4. The literacy organizer should not let roles in the organization get frozen or locked in. He must consider them fluid. These roles should be frequently reanalyzed. Questions like these should be asked: Are these roles still valid in terms of tasks to be performed? Do any role conflicts exist? Is role performance satisfactory? Can the individuals assigned to particular roles actually perform those roles?
5. The preceding should lead to frequent role negotiations between role incumbents. Duties and expectations related to various roles may be changed and reintegrated as often as necessary.
6. Literacy organizers should emphasize interdependencies between roles. Role incumbents in upper levels of the hierarchy should not be permitted to insult or tyrannize over role incumbents at lower levels of the organization. Good leadership should be admired as much as good fellowship.
7. Literacy organizations must train role incumbents to be able to perform their roles effectively. Role incumbents must be enabled to experience success, thereby developing among them even greater personal needs to achieve.

#### RULE MAKING FOR RELATING ORGANIZATIONAL ROLES

Roles must be related according to rules to create an organization. The sole purpose of making rules for an organization is to distribute power among various role incumbents. An organized power field must be created which can then perform societal work. Looked at in another way, an organization is a power field that can perform societal work. By rule making, individual wills of role incumbents are submerged in an organizational will. The organization cannot afford to leave role incumbents to themselves, to assert their power to develop a pecking order anew every day. Organizational designers distribute power within the organization formally. They ascribe authority to some role incumbents to make decisions on behalf of the organization. In other words, they establish formal chains of command.

The authority to make decisions is accompanied by the power to commit organizational resources. Again, the authority structure within an organization has a parallel communication structure. Different people have different communication rights and communication obligations. To put muscle in this authority structure, higher level role incumbents can punish or reward those

below them. The availability of rewards and punishments differs from organization to organization. Army has one set of rewards and punishments it can use. Businesses have another set. Organizations of literacy would have their own set of rewards and punishments. Some of these rewards will be monetary but more of them will be normative.

The basic organizational dilemma arises from the fact that ascribed authority and professional ability do not always go together in individuals. Those who have high authority within an organization do not necessarily have corresponding abilities. Conversely, those who are low in the hierarchy are not necessarily less competent. In today's world of specialization, the problem has acquired another aspect. In most organizations today the specialists suggest alternative decisions, but a generalist, in authority, has the veto over decisions. Again, specialists do the work but the generalist, in authority, rewards performance. That creates problems.

#### SOME LOGICAL PROBLEMS IN RULE MAKING

There are some basic logical problems about rule making within organizations:

1. First of all is the problem of anticipation. All decision-making situations cannot be anticipated so that these could be made subject to rules. In pioneering enterprises, such as literacy and other development work, anticipating situations for rule making is very difficult indeed.
2. Too much rule making stymies those who are made subject to those rules. The impersonality and rigidity of rules goes against both motivation and spontaneity. Yet absence of rules and regulations creates confusion about courses of action for role incumbents within an organization.
3. Rules cannot always be made afresh. Organizations, in fact, borrow each other's code books. Unfortunately, quite often borrowing is not followed by adaptation to particular situations of different organizations.
4. While rules regarding command can be easily developed, rules regarding co-operation cannot be. No doubt, special co-ordination roles can be created within organizations and different units can be commanded to communicate only when asked, and communicate only what is specifically required. No wonder feedback systems within organizations have to be often handled informally. They have to depend, not merely on rules, but also on goodwill.



5. Rules must be created in relation to criteria for performance and related rewards. In development organizations, however, new concepts of work have to be invented and performance cannot always be judged in terms of products or of impact.

Even those who work within literacy organizations think that to work is to work on your desk, in your office. They feel guilty about being away in the field, and about being present in their office only infrequently. On the other hand, some would carry things to the other extreme. They would suggest that "armchair thinking and desk planning" is a waste of time. That is certainly not so either. Desk work is necessary. But office work is not all of the work of a literacy worker.

As has been suggested above, a literacy worker's performance cannot always be judged in terms of products and impact. Development is a complex process. Motivations within communities cannot always be created by individual literacy workers. The door to learning and growth opens from the inside. The literacy worker can only knock at it. Literacy workers should therefore, be judged in terms of their commitment to work and in terms of the application of processes. If a literacy worker did all that was necessary and yet no literacy class materialized, you do not necessarily have a bad literacy worker on hand.

6. Finally, rules must create career lines for its workers. Within non-governmental agencies the task is comparatively easy. However, within governmental settings where officials become subject to civil service regulations problems would be many.

#### SOCIOLOGICAL COMPLEXITIES OF RULE MAKING

In rule making, as indeed in most human life, the logical gets confounded with the sociological. Here are some of the sociological problems about rule making:

1. The first problem arises from tensions introduced into the authority structure. Role incumbents bring their "personalities" with them as they join organizations. They also bring with them their social statuses, their relationships with powerful people and outside groups, and thereby their

influence and power. Also some of the role incumbents are very able and competent and develop individual power incommensurate with their official positions. This informal power structure that is not congruent with the authority structure constructed by rules generates tensions within the system. It leads to what has been called bureaupathology and bureausis defined<sup>3</sup> as follows:

Bureaupathology. When a role incumbent in high authority feels that he is really not as competent as some of his subordinates, he or she tries to hide personal insecurities by excessive assertion of authority and status. Such dysfunctional behaviour is called bureaupathology.

Bureausis. This is a word that describes the inability of some people to cope with organizations, and their childish tendency to find the rationalism, orderliness, impartiality and impersonality of bureaucracies completely intolerable.

2. In our discussion of roles we pointed out how individual incumbents re-define roles to suit their personal inclinations and capacities. This process throws rule making in disarray. New informal rules develop to support, extend and substitute for formal rules. These informal rules are so important that the organization can come to a standstill if role incumbents begin to work according to the formal rules.

3. Rule making creates divisions of labour, and organizational mechanisms, such as units, sections, departments and divisions. These mechanisms, however, come to have a life of their own, so much so that they begin to consider co-ordination with other units an unnecessary nuisance. Information is guarded from those for whom it was created in the first place. Here, again, the informal communication system helps.

4. New informal reward systems also emerge. Not only monetary but status rewards are given. Psychological contracts develop and are honoured. These psychological contracts have complex structures relating to individual's needs for security, autonomy, achievement, sense of power and self-actualization.

---

<sup>3</sup> By Victor A. Thompson, Modern Organization. New York: Alfred A. Knopf, 1961.

## WHAT CAN A LITERACY ORGANIZER DO?

What can a literacy organizer do about rule making? Some of the remedies are implicit in our discussion above. Others can be suggested:

1. A literacy organizer may be well advised not to create too many hierarchies within the organization.
2. Rules may be designed so as to allow the creation of temporary systems within the organization such as task forces, work teams and project teams. This would require perhaps that roles are named generically, e.g. as Program Specialists rather than Evaluation Specialist, Training Specialist, Field Work Specialists, Extension Specialist, etc. One can have generic role designations and yet develop specializations by naming specialists as Program Specialist (E), Program Specialist (T), Program Specialist (F), etc. But generic labelling would make redefinition of roles and role negotiations possible when necessary.
3. The literacy organizers, again, must not treat rules, once made, as sacred and good for all times. Rules should be considered as fluid and changeable. He should review them for their functionality every now and then.
4. A literacy organizer must frequently take special actions to energize the informal communication networks within the organization. This can be done by employing special Organization Development techniques for creating systematic feedback mechanisms within organizations.
5. Rules must provide for the promotion of organizational intelligence. A literacy organizer should not overload the system with reports and forms. However, an organization should not be an oral enterprise without a memory. While work proceeds, role performers must generate valid data and this data must be kept in a form which it can be readily used by everyone in the organization for informed decision making. Rules must, that is, require systematic creation and use of valid information within the organization.
6. A literacy organizer may, usefully, separate the processes of solution invention and implementation of decisions. He should separate these two processes not only in his own mind but must enable his colleagues to understand the separation as well. During the process of solution invention all possible participation should be encouraged. Points of view, information, and personal opinions must be requested. Once the decision is made the

implementation process should begin. At the implementation stage, compliance should be ensured, unless a formal review of the decision becomes necessary.

7. Finally, the literacy organizer should use rewards of status and shared credit for all workers within the organization.

#### RESOURCES FOR ACTION

Organizations cannot exist without resources. They must use resources to create other resources and services. Organizations may be seen typically to need six different types of resources:

1. Cognitive/Informational Resources
2. Attitudinal/Goodwill Resources
3. Material Resources
4. Personnel Resources
5. Institutional Resources, and
6. Time Resources.

#### CREATION AND MANAGEMENT OF RESOURCES

Literacy organizers are habituated to their poverty. Most often they have low budgetary aspirations. They do not ask for much, and they get even less.

Organizers and administrators of all kinds are often unaware of any lack of conceptual resources within their own organizations. They seem to say - "If we did not know our job, why would we be here?" Sometimes they may know of organizational lacunas but may try to build all conceptual resources within the organization. Conceptual resources available outside the organization through short-term consultants may be completely neglected. Budget procedures may not even permit consultant use. On the other hand, some organizations may have over-abundance of consultant help. Once a certain number of months of consultancy has been budgeted, there may be compulsions for squandering those resources. Goodwill is seldom looked at as a resource by literacy organizers and they may often learn, to their dismay, that personnel are not always available when they have money to pay them.

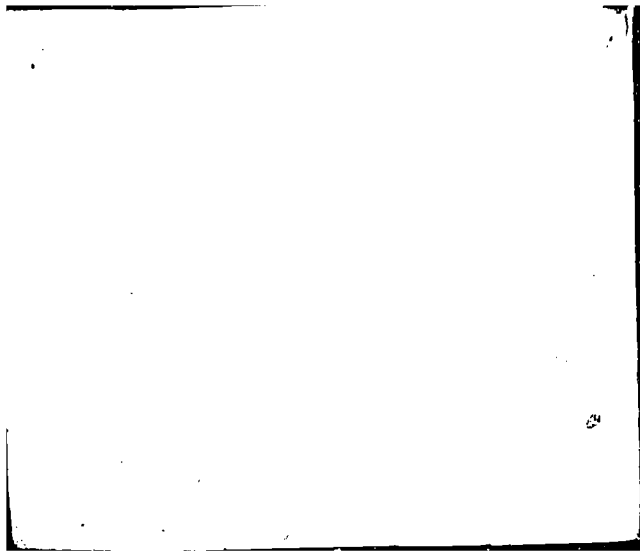

Literacy organizations often may have no institutional support and may find it necessary to build their own infrastructures. At other times, however, they may try to build their own parallel infrastructures and not use what is already available merely for the asking. Finally, time may be badly handled for want of systematic approaches to planning and knowledge of techniques, such as PERT.

#### THE HUMAN ELEMENT IN RESOURCE USE

The human element in resource availability and use plays fantastic tricks on planners and administrators. Too much of material resources can produce a goldrush. Every one may want to have a part of the money that is around. In economies of scarcities, organizational equipment and properties may be misused for personal advantage. Official cars, radios, tape recorders may be put to private rather than official use. Interestingly enough, there may be something called the "nationality of money". Money may be differently spent depending upon the sources from which it comes. American money may be different from Tanzanian money. Now probably, Iranian money and Saudi Arabian money may each acquire its own particular nationality and invite special responses from those who spend it.

Finally, organizers in control within organizations seldom try to hire subordinates smarter than themselves. And in developing societies, some seem to think as if there is room only for one reputation in the whole country. They do not realize that there is a lot that remains to be done in this world and that there is room for a million initiatives and reputations in this world.

#### WHAT CAN A LITERACY ORGANIZER DO?

Once again, the question must be asked. What can a literacy worker do about the management of resources? Literacy organizers, minimally, must develop a sharpened awareness about the human aspects of resources and must learn to manage them well. They should be careful neither to abuse, themselves, nor allow the abuse of organizational resources, by others.

## INSTITUTION BUILDING ASPECTS OF LITERACY ORGANIZATION

As we have suggested before, the processes of organization and mobilization for literacy work can be analyzed in two parts: 1) organizational design and 2) institution building. Further, that the organizational design, in turn, can be seen to consist in the design of two subsystems within the organization: i) the technical system and ii) the social system. We also indicated that the process of design of the technical system of an organization must necessarily respond to the typical characteristics of the social architecture of organizations within a society. The total organizational design process in turn, as it proceeds, must include considerations for institution building if the organization has to have the chance of survival in the society it seeks to serve.

We have, elsewhere, described the process of institution building as as organizational launch into social space. The analogy is a good one. Institution building, indeed, is a process whereby a new organization is launched into the society to become, on the one hand, a part of the partial network of related institutions; and, on the other, begins to serve a group of clients (which may include individuals, groups, institutions and special publics).

The requirement for the institutionalization of a new organization may be stated as follows:

1. The organization does not require repeated mandates from the power elite for its continuation within the society. On the other hand, its termination does involve a special policy initiative and a formal mandate from the power elite.
2. Resources needed for an organization's continuation become a long-term public charge. In the case of a voluntary organization, this condition may be fulfilled through an endowment of funds. In case of organizations where a large part or all of program funding must be collected from different sources every year, the funding for the basic personnel, facilities and equipment needs should have become a long-term public charge.
3. The values and the norms of the new organization should have become an "ideal" for at least similar or related institutions within the society.

It is not necessary that these institutions should have actually incorporated these values and norms.

4. The society which the organization serves should be able to supply the personnel and skill resources needed for the organization to function. In the language of economics, the organization should have obtained total or almost total input substitution for personnel and technology employed by the organization. The organization, that is, should have become anchored in the society.

5. The organization should not still be in the process of "fashioning" client needs. The new services being provided by the organization should have become "felt" needs for clients of those services.

In the following we will discuss how systems of action for literacy work should become institutionalized.

Literacy work is too often done by organizing campaigns. A voluntary organization or a government department, every six months or a year, gathers a team to go into the villages, gets the local leadership together, hangs banners and bunting, pastes posters on the walls, shames illiterate adults into becoming learners and the village primary school teacher, the revenue clerk or the local co-operative secretary, and sometimes the middle school children into volunteering to be literacy teachers. Some instructional materials are supplied. Once the classes have been "opened" the campaigners leave. Soon, thereafter, adults drift away, teachers lose commitment. The classes close down.

Campaigns have a place in literacy work - to create consciousness, to generate enthusiasm and movement. But literacy work cannot be done by campaigns alone. A system of action is needed to sustain enthusiasm once it has been generated. Teachers must be trained and continuously helped on the job, they must be supervised, given social rewards if not gifts of money. Learners must be helped to see what they could do with their literacy skills once they have acquired those skills.



## LITERACY AND SOCIAL POLICY

It is imperative that adult illiterates who join literacy classes should be offered more than mere mystification of literacy. The right to read means little without the right to rebel against the prevailing socio-economic order of hopelessness for adults being invited to literacy classes. The point is that a literacy policy should be congruent with and supported by a socioeconomic and political policy which offers adults genuine participation in the social and political life of the community and the country. The adult learners should be able to look forward to improved economic well being, better social status and greater political effectiveness. And literacy should be seen as playing a role in this new integration.

## THE LIFE OF SYSTEMS OF ACTION FOR LITERACY

Accepting that literacy work can not be well done through campaigns and that systems of action (organizations and organizational networks) need to be created, a question can be asked: Why should these organizations and organizational networks be institutionalized? Why should organizations for literacy be perpetuated? If primary schools do their job well, and if literacy organizations work effectively, would not the latter soon put themselves out of business? Does not a successful organization for literacy make itself redundant? Why then institutionalize literacy organizations? Why not treat them as temporary or at best semi-permanent systems?

The question is a reasonable one. But there are lots of ifs and buts involved. Literacy in most countries of the Third World would remain for long an unfinished business. Wastage and stagnation in primary education is high and schools for years to come will continue producing more illiterates than literates. The absolute numbers of illiterates have indeed increased in most developing countries even if percentages of illiteracy have dropped. In most places in the developing world, again, literacy work with women - the greater half of humankind - has barely started. Thus perpetuation of literacy work through institutionalization of organizations of literacy should not create any institutional debris for a long time in the future. But more to the point, organizations for literacy can develop into

adult education and community development organizations without serious crises of organizational identity. In today's world of engineering and social technologies, learning societies have become unavoidable. A literacy organizer's work will thus never get done!

#### INSTITUTION BUILDING: A CONCEPTUALIZATION

An organization is a system. Units, divisions, sections and departments that are part of an organization are its subsystems. On the other hand, such an organization is itself a subsystem of a larger system of a network of developmental organizations, and, ultimately of the total society. We need not stop with the nation state. The universe we live in is the ultimate system.

The process of organizational design was defined earlier as an instance of systems design. The process of institution building was also defined as a process of systems design. The difference now is that in the latter case we are dealing with the larger system into which the organization has been launched (and of which the organization is seeking to become a subsystem).

The same set of concepts that were used to discuss organizational design will be used to discuss institution-building. (See the chart on page 3).

Our discussion of institutionality should have suggested that the basic task of institution building consists in a) enabling the newly launched organization to find adjustments with and support from the existing configuration of institutions and relevant publics, b) developing linkages, both formal and informal, with actors in relevant configurations, c) coping with the environment according to whether the environment is supportive, inhibitive or neutral, and d) obtaining and utilizing resources.

#### ADJUSTMENTS WITH INSTITUTIONS AND CLIENT GROUPS IN THE ENVIRONMENT

Organizations, as social systems, need power to survive and be able to

serve their clients. Literacy organizers can build power for their organizations in various ways: i) by borrowing power from the already established institutions through the process of legitimization; and ii) by building mutual interdependence with other existing institutions and the target groups of clients.

The very fact that an organization like the WOI comes into being means the policy making elite and the existing institutional structure did provide normative support, enabled the organization to come into being and to function. At the institution building stage, one of the things to do is to be ensured of the continuation of normative support for the organization. In other words, the organizers must look for legitimization of their organizations by existing institutions. This is a transaction where the literacy organizers cannot offer much in return. They will have to refer to national ideologies, aspirations and commitments and regularly obtain verbal statements on the goodness of literacy work. Once such statements have been obtained, these should not merely be displayed on the wall of the chief organizer's office. Such testimonials must be disseminated as widely as possible among the instrumental elite and among the public.

To build interdependencies with existing elements of the total configuration is another important step in institution building. Literacy organizers should take a census of institutions, of more or less organized groups and of elite individuals who might be of help or who might already be feeling competitive or threatened. Those who feel competitive must be given their own spheres of works. They should, that is, be integrated into coalitions. If an organization already exists which is doing literacy work in urban slums or among prisoners in a prison setting, the new literacy organization should not try to encroach upon their work. Offers for training, for supervision support, for instructional materials should be made to such organizations with the utmost discretion to avoid being accused of empire building. The intention should never be to conquer but to collaborate. Those institutions, groups and individuals who can help should be approached and help should be requested. Credit for work should be shared both with competitors and collaborators.

Developing interdependencies between the literacy organization and the clients of literacy - the adult learners - is the most important and also the most complex process. In the literature of literacy (and adult education, and community developing in general) we talk of the felt needs of people. Literacy workers have successfully self-hypnotized themselves. Some have really come to believe in literacy being a felt need by illiterate adults. This is generally not so. Literacy organizers must first fashion needs for literacy, and then fulfil those needs once they have been fashioned, and become somewhat felt. Fashioning literacy needs among client groups should thus be seen as a very important part of institutionalizing an organization for literacy.

#### PROBLEMS OF LINKAGES

To build coalitions with existing institutions requires getting in touch with them. Linkages are necessary for any adjustments to take place with organizations, groups, and communities. Linkages are of two kinds: formal and informal.

#### A TYPICAL FORMAL LINKAGE MECHANISM: THE COORDINATION COMMITTEE

Vertical formal linkages between superordinate and subordinate organizations are not too difficult to establish and maintain. At least the downward flow of communications is often satisfactory. Unfortunately, the upward flow of communications in formal linkage systems is not always functioning.

On the other hand, the establishment of horizontal formal linkages between different associations and organizations is problematic. Once a network of horizontal linkages has been created, it is difficult to maintain. The most typical strategy used to create a formal horizontal linkage system is through the creation of a coordination committee. Sometimes such committees may be given names like the advisory committee or the steering committee. Typically each department, office and association concerned with some aspect of the project names an official to serve on such committees. Such committees are a flexible mechanism since all kinds of interests, governmental and

nongovernmental, church-related and secular can be represented on such committees and brought together to work. Making functional use of coordination committees, however, requires considerable follow up work on committee recommendations and decisions. If decisions made in those committees are later not communicated to all concerned both within the bureaux and in the field, the coordination committee members may end up being blocks to communication rather than being of help.

#### INFORMAL LINKAGES

Informal linkages are, again, important to the institution building stage as they are at the organizational design stage. Literacy organizers will have to develop informal linkages not only with other officials within other organizations but also they would have to develop informal linkages with community leaders and powerful individuals. Informal linkages would take place within established social structures of a society - children's playgrounds, buses or commuter trains, office canteens, neighbourhood chess teams, village wells, community centers, churches and mosques, etc. When none of these channels are available, the literacy organizer can create linkages by inviting people to informal get togethers or by dropping in on the individual with whom contact must be made.

It is not possible, within the scope of this monograph, to include any detailed discussion of interpersonal behaviour. It must be stated, however, that:

- i) Authentic, honest relationships ultimately work out better than manipulative ones. Do not try to use people for your purposes. Do not let them keep guessing. Let them know how important their help is to you.
- ii) One should not get locked into one's role and status. Too often people are much self-conscious about their roles and the statuses attached to those roles. This is especially so about people working within governmental settings. On the one hand, literacy organizers in a governmental setting may themselves feel inferior while relating with public functionaries with executive and judicial powers. On the other hand, they may

feel superior to the community leadership in villages and in the bush. Often, without their knowing, literacy organizers may develop superior airs in dealing with the poor and illiterate adults in villages or in the campo. They may deal patronizingly with adult learners, their leaders and their own teachers.

The relationship of male literacy organizers with women teachers and supervisors, and with women learners in adult classes is especially problematic: women organizers may not be given positions of real responsibility. They may be given desk jobs when they should be in the field. In mixed classes of men and women, as in Tanzania, women learners may sit in the last row and teachers may seldom teach to them.

#### LINKAGE MANAGEMENT

Linkages are not good under all circumstances. One cannot, therefore, always be building linkages. Linkage management requires that needed linkages be built but that unneeded linkages be severed. Unneeded linkages create noise. For instance, a literacy organizer cannot allow everyone in the organization to give press conferences. And if the environment because of some special circumstances becomes temporarily hostile, the organization and organizers need to isolate themselves and let linkages go dormant. There is a body of literature developing around the topic of Development Communication. This literature should be of interest to the literacy organizer interested in mobilization for literacy work.

#### RESOURCES AND INSTITUTIONALITY

We have discussed resources in an earlier part of the monograph as part of the organizational design problems. Continued availability of resources is an essential condition for organizational survival and its ultimate institutionality. The resources can come from national institutional networks and from client groups.

Material resources become more or less continuous if they become part

of the state budget. Literacy organizers might, therefore, work towards getting on the public budget list. Where the total budget cannot come from state sources, literacy organizers may work towards getting commitments to a core budget - something that will support a minimum of the program and of administrative staff, and facilities. Even where funds are collected from client groups, as private support, the target should be to establish long-term endowments. In economies of scarcities, it is not always realistic to expect local support for programs of literacy, and extension. A literacy organizer need not feel guilty about not being able to collect local funding from poor farmers and housewives - the rural poor he or she has come to help.

Private funding from individuals and trusts can sometimes come tied to particular program activities. Those who make charitable donations have their own ideas on what is better charity. People sometimes feel better about supporting the digging of a well, and of planting of trees than they do about buying bicycles for the village level workers or typewriters for an office. Funding tied to particular activities may sometimes derail an organization's program and may decrease the chances of an organization becoming an institution.

The society that the organization serves or the organization itself must begin to provide the needed personnel for organizational task if institutionalization has to come about. Literacy organizers must train their personnel, consciously and systematically, for them to take positions of responsibility as the program expands. More importantly, the literacy organizers must work with teachers' training colleges and university departments of education to get them interested in training the needed personnel and in providing the research and development support needed for implementing a national literacy program. The literacy organizations to become institutionalized must be able to use the resources and capacities of institutions that form part of the total institutional network within a society. They should be able to get continuous support from the media not merely to celebrate special days but also to disseminate information on a continuous basis. They should be able to use the postal services to issue special stamps and markers to promote literacy. They should be able to get legislation to make a "literacy increment" mandatory for workers in factories, mines, and the army. The

Iranian Sepah-e-Danesh is an excellent example of use of institutional resources of the society for literacy work.

Some of the institutional resources from within the society that we have suggested for the organizer to manage for institutionalization will be cognitive (or informational) and of influence and good will. Indeed when societal goodwill becomes available the organizational tasks will have become valued. Societies sometimes seem to have all the time, on other occasions they seem to be in too much hurry. They talk of crash programs. They are unreasonable and want social transformations of cultures within months and weeks. As part of institution-building, a literacy organizer must develop proper perspectives on time both for short-term projects, and for his ultimate mission. He must project both his short-term goals of making some communities literate as well as his long-term goal of working toward a learning society.

As we have suggested before, environments can be supportive, neutral or inhibitive. The environment for the institutionalization of literacy work has to be supportive of the objectives and the ultimate mission of literacy organization. Environments are supportive of such activities when there is an environment of hope in societies; when societies have a feeling that the achievement of society's aspirations is possible and within its means.

Literacy organizers can not play God. They cannot always manage all the institutions within a society. They cannot order coalitions and collaborations. They cannot always manage all the linkages in the way they want. They cannot rebuild the environment, order hope for all the people. All they can do is to be aware of these factors and of the possibilities that each of them promises. Institution building is an area of probabilities. By doing what we have suggested a literacy organizer can increase the probabilities of his organization becoming institutionalized. At times he may do his best and yet his organization may languish, more dead than alive. On other occasions, the organization may thrive when he did nothing to deserve the good luck. Circumstances are sometimes stronger than men are, but men must try - with understandings.



## APPENDIX I

NOTES ON A POLYVALENT CENTER  
AND THE DANISH FOLK HIGH SCHOOLS  
(By Joginder K. Bholra)Polyvalent Center (Shramik Vidyapeeth, Bombay)

The Polyvalent adult education center, an innovative educational set up for urban industrial workers established in 1967 in Bombay, India focuses on the wholistic development of an adult. The center is managed by Bombay City Social Education Committee which is assisted in its organizational efforts by Shramik Vidyapeeth Samities--local planning and promotion committees. Financed jointly by the Ministry of Education, labor organizations and student fees, the center provides tailor-made educational programs of two to eighteen weeks duration for an individual's economic, social, cultural and political development. A principal, a small number of full-time and a large number of part-time instructors and a small secretarial staff are responsible for the educational activities; but regular assistance is sought from the community, other educational institutions and social and cultural organizations. Over a period of ten years, the catalog of programs has increased from general and technical education to services like distribution of follow-up materials, vocational guidance and placement, information dissemination, consultation and promotional activities.

Philosophy of the Polyvalent Center. The philosophy behind a polyvalent center is to provide polyvalent education which attends to the multifaceted needs of the worker. It looks at man as a whole being: man at work, man in his civic and family roles; man as an individual in the process of developing into a full being by enriching his professional, intellectual, moral and aesthetic faculties. Thus, the programs attend to the multifarious aspects of the individual's learning needs: programs are framed according to the individual needs; they are designed to suit the background and current level of the worker; programs have interdisciplinary approach to them; they are organized to suit the convenience of the participant; and programs involve learners, employers and community resources as well as resource persons.

Goal of the Center. The goal of the center is to provide a comprehensive, all encompassing set up through which a learner gets opportunities to prepare himself more adequately for vocational skills through general education; to improve his vocational skills and knowledge for raising his efficiency and productive abilities; to develop a right perspective towards work and to enrich his life by better understanding of himself and his environment.

Organization and management. The management and organization has also a polyvalent approach to it. Polyvalent center is managed by Bombay City Social Education Committee which is advised by the Shramik Vidyapeeth Samiti, a committee

consisting of representatives from worker's organizations, central and state governments, Bombay Municipality Corporation and professional experts. Shramik Vidyapeeth Samiti is assisted by subcommittees such as a staff assessment committee, a program and finance committee, a public relations committee and a staff selection committee. All these committees are actively involved in planning and promoting of the center's activities. A principal, a small number of lecturers, administrative staff, a public relations and liaison officer are responsible for implementation of the programs. A large number of 350 part-time teaching staff members are currently utilized from the community and other institutions. There is a horizontal integration of educational, social and cultural agencies for the utilization of community resources and institutional facilities; and there is vertical integration of managerial committees. This kind of coordination organizational set up is very important for providing polyvalent education.

Programs. The center provides three types of programs: formal, non-formal and informal. Formal programs provide school type education to adults. Non-formal programs vary from literacy, post-literacy, technical courses like welding, TV repair, canteen management, home sewing, scooter repair, child-care, to effective communication and librarians' training. In all, 195 need-based programs have been developed and implemented. The duration of the courses is from two weeks

to eighteen weeks, five days a week, for a period of one to two hours each day. Most of the courses are provided at night so that the workers can earn while they learn. All of the courses are provided at different places through different institutions, by different teachers but under the management and organization of the polyvalent center. The programs are constantly evaluated and modified. Follow-up materials like magazines and newsletters published by the center are distributed free of charge to past participants. Workers also participate in writing and editing of these materials. Vocational guidance and placement services are available to the worker's children at the center. The center also collects and disseminates information regarding recreational centers, films, parks, free health clinics, placement agencies, cooperatives and self employment for the benefit of the workers. Informal programs like annual get-together, film shows and exhibitions are also arranged for social and cultural development of the workers. Consultation services are available to other organizations interested in conducting similar programs.

Critique. Over a period of ten years, the center has implemented 400 programs for economic development and 291 cultural programs for social, cultural and creative development of the individuals. It might seem pretty small operation for a huge country like India but the success of Bombay Shramik Vidyapeeth has opened the possibility for many more centers

to be opened in the near future. I wish I could find something about the admission policy to determine the efforts, if any, which are made to bring the illiterates and their children into the mainstream. On the whole the philosophy behind these centers is very healthy and has great potential for providing individual fulfillment and for nation's socio-economic development.

Implications for other countries. Polyvalent centers, build around the philosophy to provide opportunities for life long learning for the wholistic development of workers, structured around the individual's social and cultural environment, through flexible schedules, has a great potential for other developing countries. The polyvalent approach towards the utilization of the communities' existing resources saves the scarce resources of the community. It provides for the utilization of talent in the community in an innovative way. Again, this approach emphasizes the use of human resources rather than sophisticated technological resources for the increase in country's productivity. Thus, it provides employment to the unemployed, while helping the aspiring adults for fulfillment in their careers and lives, at the same time it helps the nation's economy.

Since most of the developing countries are facing the same kind of problems as those of India, this institutional approach for imparting post-literacy education is applicable as it is. All the programs will have to be need based and

indigenous in nature but the structure and the philosophy are importable. Its special strength lies in the vertical and horizontal integrations of the management committees and institutions.

### Danish Folk High Schools

According to the New Encyclopaedia Britannica, 1977, Danish folk high schools are (founded in 1844) partly state supported secondary boarding schools for adult men and women, located all over Denmark, and directed toward arousing an interest in the history and spiritual life of the Danish people. After Denmark's defeat by Prussia in 1864, these schools were a powerful instrument of national regeneration. There are no examinations, and no entrance qualifications; attendance is completely voluntary. A government grant is given to schools on the basis of a certain minimum enrollment. Most of the students are from rural areas but two of the high schools are for workers and have primarily urban enrollments; one is an international folk high school which draws its students and teachers from various countries.

Historical background of folk high schools. The political unrest at home and abroad had been a great factor in the establishment of the Danish folk high schools. The feudal system was breaking down and there was demand for democratic participation in the political and economic life of the country. The wars with Prussia had resulted in Denmark's loss of Norway and the ferment caused by the French Revolution

Revolution had spread to Germany. As a result two duchies Holstien and Schelsberg got annexed to Germany in return for free constitution. The defeat of these duchies had great impact on the Danish nation and became instrumental in hastening the democratic process. The peasants soon found out that they needed education and leadership skills to participate effectively in their country's social, economic and political life. And thus the folk high schools came into being in 1844.

Philosophy of Folk High Schools. Philosophy of folk high schools is to have belief in the common man, his abilities and intelligence. It believes in freedom for education as a fundamental right of every human being for the development of healthy and vital personality. It deals with real life, the national and cultural life of man. Even though the programs provided through folk high school are concerned with citizenship training and liberal education for democratic society, the stress is on the wholistic development of the individual.

Goal of Folk High Schools. The goal of the folk high school is to provide an institution in which the students practice democratic process and learn the leadership roles through practice. Therefore, the purposes of the programs are to provide citizenship training for taking an enlightened part in democratic government and international cooperation; to provide education for self improvement in a broad

humanistic sense; to bring common people into contact with high thoughts and to assist them to aspire for the highest ideals of character and community feeling.

Programs. The curriculum mainly consists of liberal education subjects like language, history, science, literature, music, religion and mathematics. Later on, some vocational courses have also been added, as well as courses for international understanding have been introduced.

The programs are open to any adult man or woman who will like to have opportunities and experiences for performing the role of a disciplined and responsible citizen in a free society. There are no entrance requirements, and no examinations are given or certificates are awarded after courses have been completed. In such atmosphere of freedom, adults learn without fear of failure and evaluation.

The mode of instruction has been lecture but as the time passed discussion groups, study groups and research have also been introduced.

The duration of the courses remains mainly the same: five months for men and three months for women. But courses of different durations have also been introduced for parents and pensioners.

Organization and management. Folk high schools are residential schools, mainly for peasant communities but any one can take advantage of them now. Originally, the school was organized around a leader called principal who was



personally responsible for its continuance. The students and the lecturers along with the principal stayed in the same house and shared all the responsibilities. A little modification has been made as the organization has become bigger. The teachers can now live outside the school building, provided the distance is within the prescribed mileage. The principal is still the key figure, but schools which are owned by associations or are endowed have better chances for survival than those which are privately owned and operated. The students provided for their tuition and board and lodging in the early years of its existence, but later on government began awarding grants to schools as well as to the needy students.

Critique. The folk high school's form and philosophy has remained the same though the curriculum and course durations in some cases have undergone a change. These schools have proved to be a great institution and have remained in existence since their inception in 1844. This movement did not remain confined to Denmark alone but spread to Norway, Finland, Switzerland, Germany, United States and many other countries. The reason behind its success is its form and philosophy of flexibility. The origin of seminars, workshops, weekend courses, farmers' cooperatives, university extension services can all be traced back to these folk high schools.

Implications for developing countries. There is a great applicability of folk high schools for developing countries, struggling to bring their rural populations in the mainstream. The form of these schools particularly suits those countries whose populations are scattered all over their lands. They can bring their publics in the residential institutions for providing education in the democratic processes as well as in the new technologies needed for improved productivity. Again, selected adults can be trained from the rural populations who in turn can educate others in their own villages. The philosophy of flexibility of programs, open admission, nonexistence of tests and grades, particularly suits the conditions where most of the adults are made literate through the literacy classes and do not have formal credentials for further education. Furthermore, this kind of institution provides for real learning environment. The developing countries have to import only the form and philosophy but have to create courses relevant to their needs and resources. They can develop courses for literacy retention, citizenship training, vocational training, and any other training required for the development of human beings and ultimately their nations.

APPENDIX F  
LEARNING RESOURCES FOR COMMUNITY EDUCATION:  
DESIGN NOTES ON DELIVERY SYSTEMS

By  
H.S. Bhola  
Professor of Education  
Indiana University

November 1977

---

These design notes were developed as part of the author's consultancy to the USAID/San Jose State University project, "Learning Resources Center-Based Community Education Systems (LRCBCES)," Project No. 598-15-670-573.

## TABLE OF CONTENTS

	Page
I. Introduction . . . . .	1
II. Learning resources for community education: the first rung .	2
Learning resources for a learning society . . . . .	3
Profitable investment and distributive justice. . . . .	3
Who is at the first rung? . . . . .	4
Community education in small communities. . . . .	5
District learning resources centers: the backup system . .	8
III. Learning resources for community education: the second rung.	12
Communities at the second rung. . . . .	12
Community learning resources center (CLRC). . . . .	12
Some CLRC scenarios . . . . .	13
Scenario, I: Community education in San Simón De Cocuy, Venezuela . . . . .	16
Scenario, II: A community center in Peru. . . . .	20
IV. Learning resources for community education: a multimedia mega center. . . . .	24
The dilemma exists but is possible to resolve . . . . .	24
Institutional arrangements for a multimedia mega center . .	27
Policies on procurement of instructional materials. . . . .	28
Special projects: a part of the whole. . . . .	31
Criteria for establishing special projects. . . . .	31
Examples of special projects. . . . .	32
Designing in context, by objective. . . . .	33
Two roads to the same destination . . . . .	33
Conclusions . . . . .	34

## LIST OF FIGURES

- Figure 1. A plan for the utilization of learning resources for community education for community action showing DLRC's supporting community education groups (G's) within first rung communities. . . . . 6
- Figure 2. A working sketch for a DLRC to support community education in the first rung communities . . . . . 11
- Figure 3. A proposed design for a CLRC for a community in Venezuela . . . . . 18
- Figure 4. A community learning resources building and its component parts . . . . . 22
- Figure 5. The elements of a multimedia mega center, showing a possible pattern of separation and independent institutionalization of various elements . . . . . 29
- Figure 6. Appropriate learning resources in various institutions at various levels, resulting in a learning resources system for a learning society. . . . . 35
- Figure 7. A comprehensive, national system for the delivery of community education for community action, with learning resources components built into the system at various levels. . . . . 36
- Figure 8. A network of community centers under a special project, each self-contained in terms of learning resources facilities. . 37
- Figure 9. Community centers under a special project being served from a central learning resources center. Such a central learning resources center could at some later time begin to serve clients other than those served by the special project. . . 38

## INTRODUCTION

A comprehensive and adaptable system of organizational arrangements is proposed that will enable educational planners in Latin American countries to develop and deliver learning resources for use in programs of community education for community action. A three-tier system of learning resources centers is proposed: a multimedia mega center at the highest level, followed by district level learning resources centers (DLRC's) and community level learning resources centers (CLRC's) in communities of size and need that could support such centers. It is suggested that in small communities of 2,500 or less, it may not be advisable to establish independent learning resource centers. Community education services should be provided to such communities on an urgent basis by establishing community groups of various kinds in such communities.

These design notes were developed as part of the author's consultancy to the USAID/San Jose State University project, "Learning Resources Center-Based Community Education Systems (LRCBCES)," and submitted to the project director in the form of three memoranda, now appearing as parts II, III and IV of this paper.

LEARNING RESOURCES FOR COMMUNITY EDUCATION:  
THE FIRST RUNG

Elsewhere, we have discussed the nature of community education for community action including normative criteria for judging both means and ends of community education.<sup>1</sup> We have also presented, in another paper, a conceptualization of the use of learning resources in community education for community action.<sup>2</sup> The second paper sought to underline the challenge in coordinating organizational actions and instructional actions that actualize national visions on the one hand and fulfil local needs on the other.

In this paper, we engage in "progressive conceptual focussing" to conceptualize, in greater detail, the use of learning resources, and the organization of their delivery, for community education at the first rung of what will, ultimately, emerge as a multilevel national system of learning resources for a whole "learning society."

We must caution the reader by saying that this is not presented as a firm plan for every country on the use of learning resources in community education for community action at the community level. This is still nothing more than a planning model that suggests some institutional solutions which have to be evaluated and adapted to the realities of the region or the country where this model is put to work.<sup>3</sup>

---

<sup>1</sup>H.S. Bhola, "Community Education for Community Action: A Multiframework Mega Model," a paper prepared for the USAID/San Jose State University project Learning Resources Center-Based Community Education Systems (Project No. 598-15-670-573), 1977.

<sup>2</sup>H.S. Bhola, "Conceptualizing the Use of Learning Resources in Community Education for Community Action: An Integrative General Model," another paper prepared for the project described above, 1977.

<sup>3</sup>An institutional solution may involve the invention of new organizational mechanisms or a restructuring of existing organizations. Second, it may involve the invention of new instructional or organizational roles to carry out the new institutional purposes.

The vision of a learning society presented almost a decade ago by Hutchins, an American educator, seems like a practical ideal today.<sup>1</sup> Some communities of North America and Western Europe have already become learning societies and have created the learning resources needed for those learning societies. Societies of the Third World are now creating small parts and elements that would, in the future, come together as learning resource systems for a learning society. The present emphasis on nonformal education and community education is one ray of hope. The new communication media resources in various forms and with various institutional sponsorships are parts of the network which is slowly but steadily emerging. Literacy is spreading as is the transistor radio; the two viruses for a learning society.

Here, then, is the first bit of planning advice. Whatever little is done by community educators, by way of production, organization and utilization of learning resources for community education in their communities and regions, must be considered a link in the ultimate network of learning resources for a learning society. This would put all such work in a larger national perspective. The realization that every little effort would have a cumulative effect would provide community workers with a needed sense of optimism.

#### Profitable investment and distributive justice

There should be another dividend from bringing this larger perspective to bear on community education work in communities and regions. Community educators should become aware of their invisible clients, not living in

---

<sup>1</sup>Robert M. Hutchins, The Learning Society, New York, N.Y.: Praeger, 1968.



their particular community, but yet part of their society. This should lead to an understanding of the need to make their investment in learning resources as profitable as possible. In other words, materials produced for one community, within one program, should be made available to every person and community that wants them and can use them profitably. Understandably, some of the learning resources produced within a local program will be useful only to that local community but other materials would, most likely, be of interest to others. Such materials must be accessible to others for the total society to profit as much as possible from their investment in learning resources. This would mean not only good economics but also serve the interest of justice in the distribution of information and education.

Such general use of some of the material produced in the specific context of local programs or special projects would demand that institutional arrangements be made whereby such multiple use of materials is in fact made possible. This would, at least, mean the establishment of some kind of learning resource centers which, among other functions, will assume the function of serving as repositories of such materials and will then be able to catalog and distribute such materials to those who want them.

#### Who is at the first rung?

In this paper, we seek to discuss the use of learning resources (and their organization) for community education at the first rung of a multilevel system of learning resources. But who is at the first rung? What kinds of communities and families do we have in view? We have in mind small communities. But how small has a community to be, to be a small community? This is indeed a difficult question. Our answer is that perhaps a community of less than 2,500 men, women and children could be considered a small community. It would be a community that for reasons of small size and/or

problems of resources can not afford a community learning resources center of its own.

Those communities that support populations between 2,500 and 5,000, we will categorize as communities at the second rung and we would suggest models of learning resources for such communities in Part III below. We will call such learning resource centers at the second rung Community Learning Resource Centers (CLRC's).

As Figure 1 (page 6) would indicate, we have made provision for learning resource centers at the district level. We have called them District Learning Resources Centers (DLRC's). These will be discussed as part of this section.

The Special Projects are a class apart and, again, will not be discussed here. Finally, the national network of learning resources for a learning society will be discussed elsewhere as also the problems of urban community education.

#### Community education in small communities

In addition to the normative assumptions about means and ends of community education for community action made in the two papers cited earlier, the following have entered our considerations as we suggest this model of community education at the first rung of the system:

1. Community education systems should be built from the bottom up. Beginnings with community education should be made with the most remote, underprivileged and isolated communities. One should avoid the temptation to start working where it is the easiest to act.
2. The community group should be the primary setting for instruction, discussion, action, and evaluation. This would mean the establishment of discussion forums based on radio listening and other learning resources.
3. Communities should take most of the responsibility in defining objectives,

Learning Society Networks

NATIONAL LEVEL

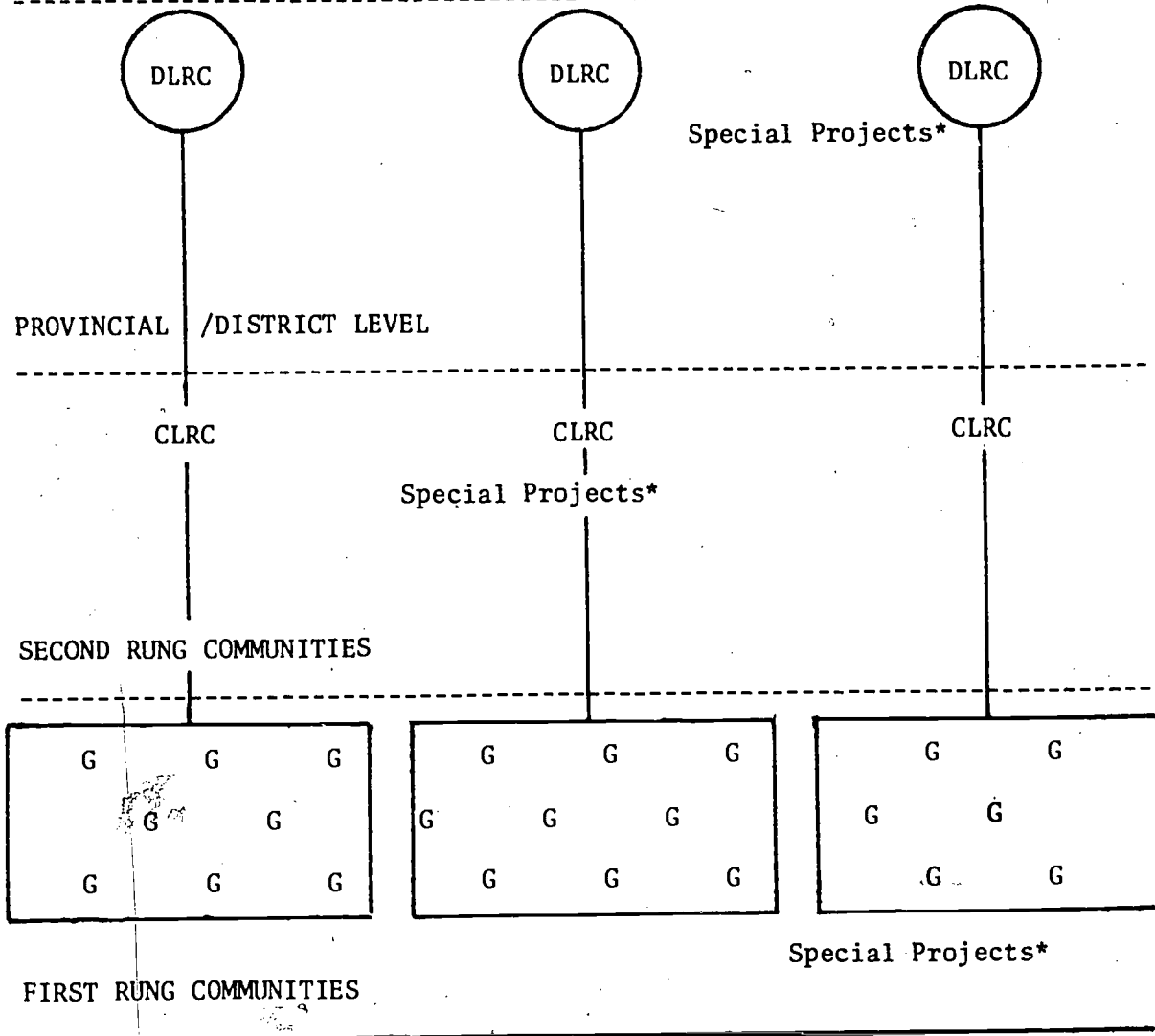

Figure-1. A plan for the utilization of learning resources for community education for community action showing DLRC supporting community education groups (G's) within first rung communities.

organizing instruction, promoting motivation and action, and evaluating results. (This should not mean benign neglect of communities by community educators at the district and national levels. Indeed, this would require important inputs from these levels and subtle and significant contributions to cultural dynamism.) As part of the scheme for local initiative and local responsibility, "Self-Help Brigades" or group such as "Men/Women/Youth for Better Tomorrow" should be created.

4. While one or even more "community centers" may be constructed by local people, using local construction materials, and by contributing labor, an LRC need not be created in every community. Indeed, it would be unrealistic to create LRC's in such small communities. After all, learning can take place with learning materials but without a learning resources center.

5. We must use what already exists: existing social organization, existing instructional/socialization roles, communication patterns and traditional media.

6. In terms of newer media and materials, we suggest three: radio, picture sets, and prepackaged instructional kits. Films may be shown occasionally if the realities of the situation permit. Radio would be in the community, perhaps, already. If it is not there in a community, it is easy to introduce. Radio requires no infrastructure of roads and railways and is the medium of community education par excellence.

Production costs are low. And delivery costs have been sometimes as low as 2¢ per person per hour. Mounted pictures or photographs in size of 18" x 14" are another useful medium of instruction. Pictures dispense the need to have projectors, electricity or batteries. When mounted on strong hardboard, they can last quite long. Instructional kits that include pictures, models, specimens and other instructional material are another obvious choice.

7. It should be understood that even if there is one literate in a whole community, his presence makes it possible for the community to use written materials. If any literate person lives in the community, then written materials should become part of the instructional strategy.

District learning resources centers: the backup system

If such a program of community education is envisioned at the level of first rung communities, the following needs become, immediately, clear:

1. Need for animation at the community level which means cultural action on the part of suitably trained and sympathetic outsiders. In other words, we need a community organizer role.
2. Need for radio broadcasts to be used in radio discussion forums; picture sets on the themes of agriculture, health, nutrition, family planning, etc., kits of various kinds; folders, leaflets, and perhaps tin trunk libraries for circulation in the communities; and
3. Need for training of local cadres.

Thus, we need a DLRC with the three objectives of:

Production and procurement,  
Training, and  
Field organization.

We are not suggesting that new DLRC must be established in each case to begin initiatives in community education. Reference is made here to our discussion of institutional integrations in the mega model which suggests how existing institutions might be restructured to fulfil the functions proposed for a DLRC:<sup>1</sup>

Radio broadcasts. Radio broadcasts should be the most important production activity of a DLRC. The radio transmission facilities may be

---

<sup>1</sup>Bhola, Mega model, op. cit., section E.

owned by the DLRC or may be available to the DLRC for part of the day in consideration for money paid.

Tapes of select programs should be prepared for repeated use; for availability to users outside the area of broadcasting, and even in other Spanish speaking countries; and for use within the communities when cheap tape-recorders become available within the foreseeable time.

The DLRC should also prepare folders, leaflets, and booklets to be read by literates living within these communities or to be used by literate animators with their illiterate brethren.

Picture sets. To communicate information that requires pictorial presentation, the DLRC's should produce picture sets of photographs and graphics that go with radio broadcasts or can be used independently within discussion forums to learn and to make decisions on various aspects of agriculture, health and nutrition.

Learning kits. Some learning may require more than pictures and graphics. Actual specimens and other realia may be necessary. For this reason DLRC should also be preparing some learning kits for use in the first rung communities. These kits should be assembled in boxes made of hard plastic so that they could be transported over large distances without damage.

Tin trunk book libraries. The DLRC should also function as the headquarters for a network of mobile tin trunk libraries of books. These libraries may be nothing more than 30-50 books in a tin trunk that may be left in a community wanting it for 2 to 3 months. New books may be brought to the library when possible, while some old ones may be removed. The tin trunk library may itself, move from community to community depending upon need and requirements.

Training materials. The DLRC should also prepare training materials

to be used by its community organizers in the training of cadres in the field. These training materials could be in the form of tapes, slides and exercises that trainees can work with to learn and to evaluate their performance.

A working sketch for a DLRC is included on the next page. The organization of learning resources centers for the second rung communities will be discussed in a subsequent section.

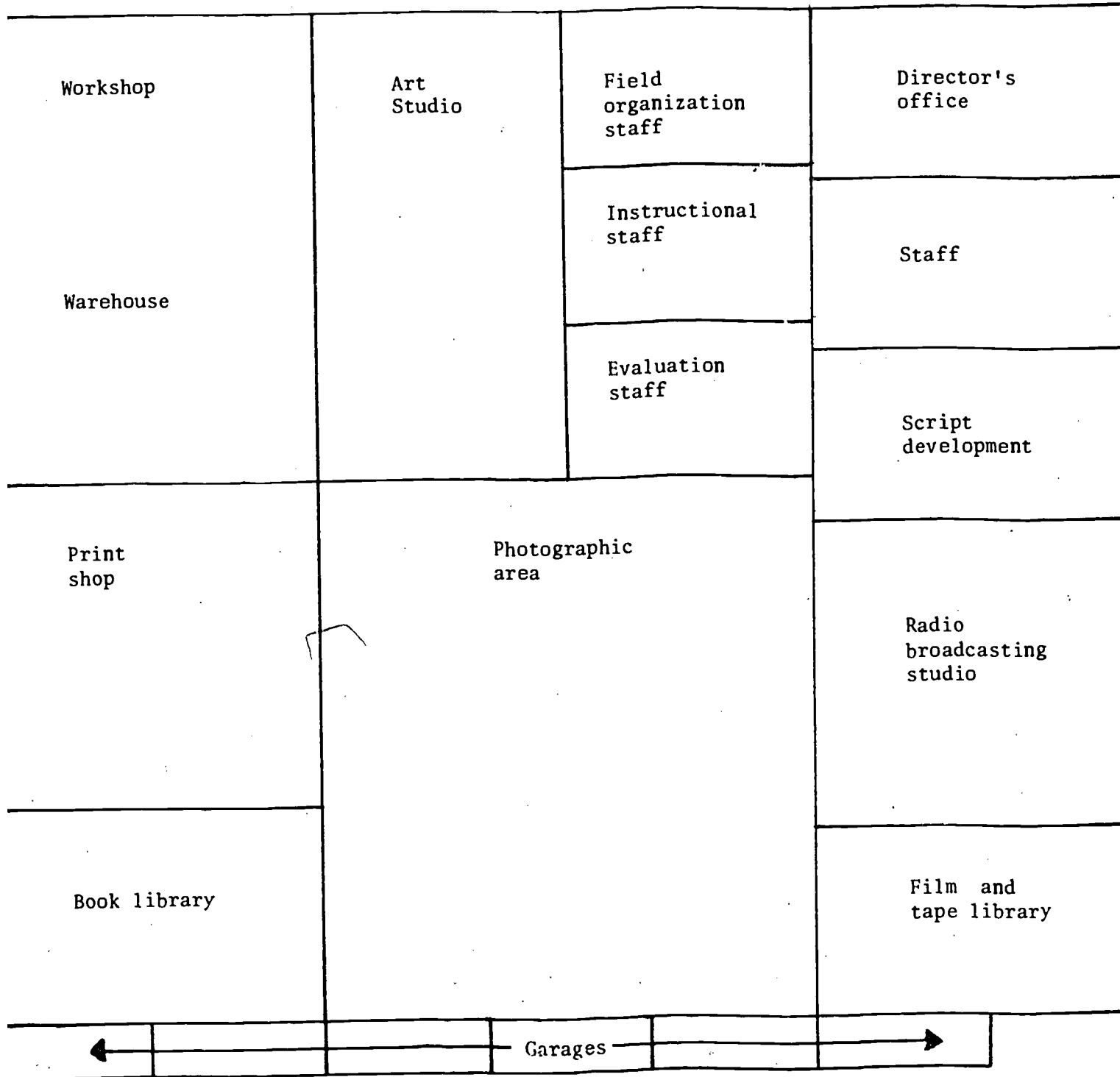

Figure-2. A working sketch for a DLRC to support community education in the first rung communities.



## III

LEARNING RESOURCES FOR COMMUNITY EDUCATION:  
THE SECOND RUNG

In the preceding, we have discussed a possible method for the delivery of community education to small communities of less than 2,500 men, women and children that for reasons of size or scarcity of resources were unable to have a Learning Resources Center (LRC) of their own. We pointed out that the best thing to do initially in such communities would be to establish small discussion and action groups to be serviced from District Learning Resources Centers (DLRC's). The DLRC's were assigned three main tasks of (a) production and procurement of learning resources, (b) training of personnel and local cadres, and (c) field organization. A brief description of a DLRC was also included in the preceding section. In this section, we will attend to the needs of the communities at the second rung as they prepare to participate in community education for community action.

Communities at the second rung

At the second rung of the system, we place those communities that are between 2,500 and 5,000 people, with homes and farms so organized that a Community Learning Resources Center (CLRC), when built, would be accessible to almost every one who wishes to use it.

Some of these second rung communities may be much larger than 5,000 people. In such a case, more than one CLRC could be built in the same way that some communities must be served by more than one elementary school.

Community learning resources center (CLRC)

The first basic principle that could be stated in the planning and organization of the CLRC would be that a CLRC should be community-centered but not community-bound. It should be community-centered in that it should

be planned, constructed and programmed to serve the needs of the particular community where it is located. However, it should not be community-bound in the sense that it begins to see itself as self-contained in relation to the total network of learning resources and isolated from the total learning society.

Such CLRC's should borrow materials from the national network of learning resources (to be described later), and should depend heavily upon the production, and training services of the DLRC's. The relationships among these centers at three different levels should be mutual and reciprocal. Materials developed within the special context of the CLRC's should be made available to the DLRC's and even to the institutions that constitute the national network of learning resources and materials. On the other hand, some CLRC's may have an outreach program that serves the first rung communities that we have discussed before. Thus instead of all first rung communities being served out of a DLRC, some of those may be served out of CLRC's.

#### Some CLRC scenarios

Once, again, we must raise some caution. As planners conceptualizing the use of learning resources in community education for community action, what we can suggest here are some criteria to be kept in mind while planning CLRC's for the second rung communities; and a couple of different designs resulting from the application of those criteria in hypothetical situations. We offer no prescriptions that would be good for all communities in Latin America, for all times! Local policy makers and their aids operating within their own socio-political, economic and institutional realities will have to design their own situation-specific solutions once they have learnt these general conceptual skills. It is possible to conceive that some solutions invented by local policy making groups do not even include the establishment

of a CLRC. Different kinds of teaching/learning philosophies would lead to choices of different media of instruction or self-instruction. That may mean different kinds of center facilities and differential use of space available in a CLRC. The organizational and instructional roles and cadres developed for the community education program must also differ significantly from region to region.

We suggest the following criteria in the organization of CLRC's:

1. Community organization and community education should begin first. A CLRC should not be mechanistically nailed on the community from outside, but instead the need for such a CLRC should grow from within the community. In other words, the community should decide if they really do need a CLRC. The center should not be allowed to stand in the way of community education.
2. If the need for a CLRC is felt, or has been understood, it should be planned in collaboration with the community. The choice of location, the facilities it should have, the relative contributions of government and local peoples to the construction and maintenance of the center should all be discussed fully and carefully within the community.
3. The plans for a building, if a building is planned, should be shown to a suitable architect. The choice of the architect itself is crucial. The building should be ecologically congruent with the environment. Local materials must be used in the construction of the CLRC, also, as far as possible, local labor.
4. The choice of learning methodologies and of media should be congruent with the existing cultural realities. Yet it would be absurd to go out of the way to be conservative and not use the newer media that are available. This would mean that traditional media would form the core of teaching-learning at such CLRC's. Among the new technologies would be radio, tape recordings, polaroid cameras; in some cases, hand-held TV cameras with facilities for

video-tape viewing; rural newspapers, library of books, specimens and realia arranged as a museum, perhaps.

5. The CLRC should not be allowed to become elitist in terms of its programs and in terms of the media technologies it uses. Yet, it would be tragic to be contemptuous of the people it seeks to serve. Such a CLRC should be conceived of as a "common man's university" and should ultimately fulfill all the instructional needs of such communities.

Two different scenarios for such CLRCs in Latin American countries follow.

## SCENARIO, 1

Community Education in San Simón De Cocuy, Venezuela

The following scenario for a possible CLRC was developed by Ms. Bette Booth as a project for the graduate seminar, Education and Change in Societies (H560), taught by Professor H.S. Bhola in the School of Education, Indiana University, in the Spring of 1977. To enable students to put their ideas on development, modernization, institution building and education to work, a design exercise had been included as part of the course requirement. This design exercise required that the student study the political, socio-economic and existing educational and communication infrastructures in a country of his or her choice and then propose a community education system, for the rural masses in that country, leaning heavily on the use of learning resources. A paper by the present writer, entitled, "Community Education for Community Action: A Multiframework Mega Model," was made available to the group as a background document.

The community, Bette Booth is designing for, lies in the Venezuelan Amazonas and resulted from the colonization effort of the Venezuelan government through a special developmental agency, the CODESUR.

San Simón De Cocuy is one of a cluster of three or four communities, in the midst of the Amazon jungles, far away from everywhere else. While it is isolated, it is not inaccessible. An all-weather runway and a road connect it to the outside world and the capital city which has the resources generated from the nation's oil wells and has the will to colonize the area. Thus, it is an interesting case of community education participating in the very birth of a community rather than serving the educational needs of a community with a history and tradition. It is community education for social construction rather than for reconstruction.

The ethnic and class mix of the community which is fast emerging is complex: members of the Indian tribes still roaming in the Amazonas (the Maquiritare, the Waica, the Yanomano); some from the Indians of the river culture who as farmers, hunters and traders are familiar with the ways of the Latin people, and the Latins themselves who have come as military officers, elite development officials and entrepreneurs. The CODESUR has done a lot of social and scientific research to do the best job of colonization possible. They have plans for agriculture, health, small and large scale industry, collective decision making at the community level and of saving the traditional forms of culture including the folk art forms of the jungle cultures.

The curricular aspirations of such a community have been seen, by Booth, to include literacy teaching in Spanish, history and folklore, agriculture, nutrition and childcare, construction and crafts, leadership training and conscientization. Understandably, the group is seen as an important setting for community education. Therefore, the establishment of radio forums has been emphatically recommended.

To actualize the above curricular aspirations, the following staff has been proposed for the CLRC:

- agricultural extension agent
- home extension agent
- health educator
- information officer with assistants to include media production staff, radio production staff, and library and media coordinator

It is recommended that the training of this staff should be given special attention. They should learn to be social catalysts without coming to be in charge of the community they are really meant to serve.

A rough sketch of facilities to be built in such a CLRC is proposed on the next page. Notice the inclusion of the Latin patio in the architectural

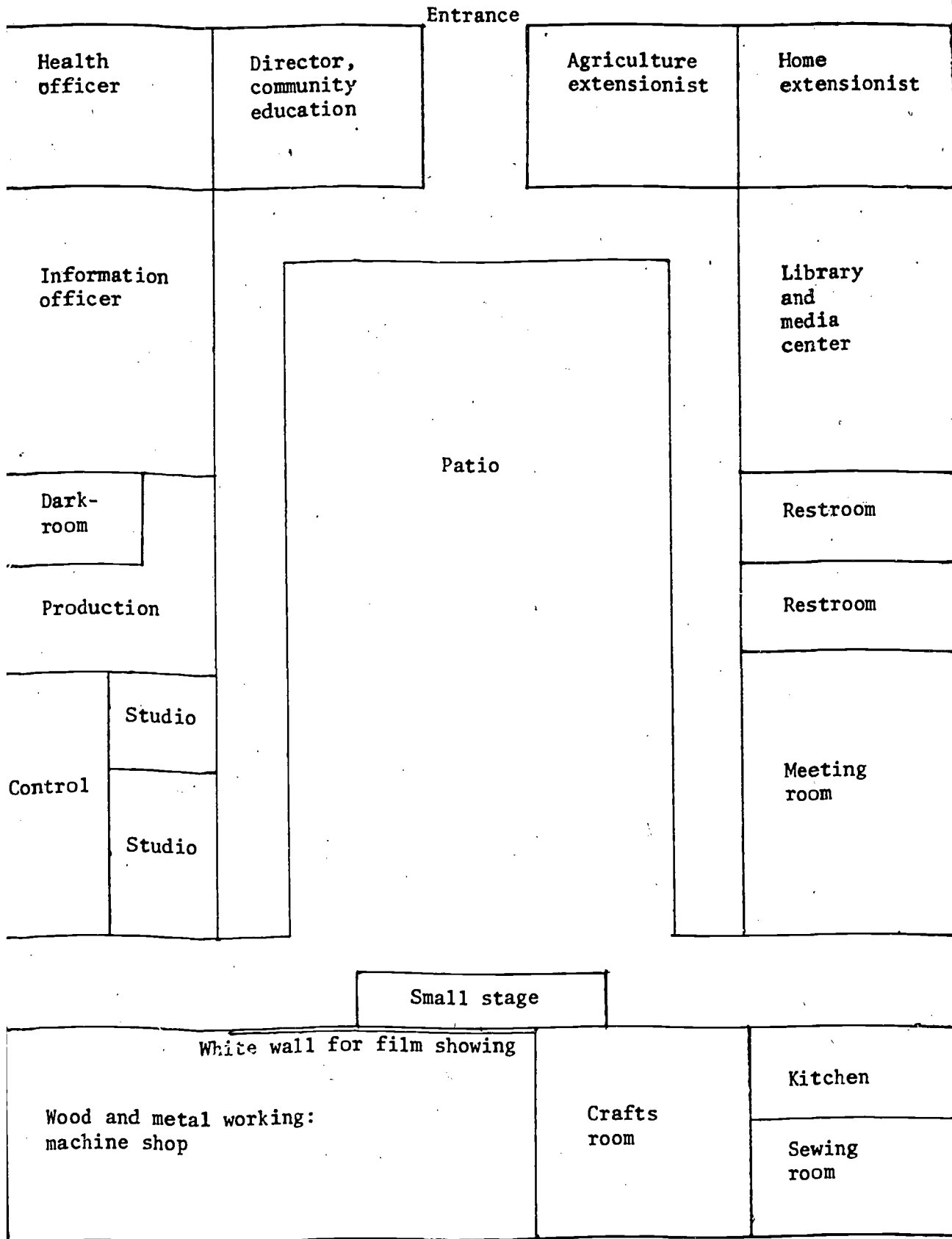

Figure 3. A proposed design for a CLRC for a community in Venezuela.

design of the CLRC and the uses to which it could be put in the tropical climate of Venezuelan Amazonas. Notice also, the separation of the workshops and kitchen from the main building.

Booth emphasises "small media" as defined by Wilbur Schramm. Radio once again plays the central role. Money is not a problem here, and there is no radio station nearby to hook into. So, a radio station is planned for the CLRC itself. Books are given a place of pride. Other equipment proposed for the center is:

Films and film projectors

Slides and slide projectors

Tapes and tape recorders

Slide tape presentations

Records and record players

Electric typewriters

Duplicators

Cameras, especially polaroid cameras.



## SCENARIO, II

A Community Center in Peru

This is the second scenario that resulted from H560, Education and Change in Societies, a seminar taught in the School of Education, Indiana University, by Professor H.S. Bhola, in the Spring of 1977. The scenario was developed by Ms. Barbara Amen. It should be noted that Ms. Amen had not had any first-hand experience of the cultural, political and socio-economic realities of Latin America. The scenario was developed on the basis of Peruvian realities as written up in books and other documents.

Amen designs for communities in Peruvian Sierra dotted by small, free holding communities of the Quechua-speaking Indians and ill-organized haciendas of the Mestizos where the Indian works. She notes that most of these communities live by farming and herding sheep and llama; and some send men out to work seasonally in industrial and mining centers. She notes also that the Sierra Indians do have a form of community government based on tradition which elects local leaders and already provides channels for community action. She notes also that traditional cultural norms of the Indian teach restrain, disapprove of display of emotion and forceful behavior, and even self-expression as we understand it. There is a lack of emphasis on personal uniqueness and focus on the needs of the social group. Appropriately, Amen makes the suggestion that we take these positives and negatives in view as we plan community education for community action for these communities in the Peruvian Sierra.

Rightly so, Amen's interest is in learning needs first, and in learning resources second. She calls her center a "community center" rather than a "learning resources center." In operational terms, however, the distinction is lost because the community center as proposed by her, does become a place

where learning resources are stored and utilized.

Amen focuses on four program elements: (1) nutrition, (2) agriculture, (3) literacy and (4) folk arts and crafts. She suggests two clear phases in the program, one building upon the other:

First phase

Nutrition, emphasis on protein intake, especially of pregnant mothers

Agriculture, also vegetable gardening

Training in speaking Spanish

Folk arts and crafts for extra income

Second phase

Becomes a more comprehensive program, includes training of local cadres of health workers

Perhaps the introduction of new crops, leads to purchase of tools and some agricultural machinery, also agro-industry such as dairy farming and tanning of skins, canning, and wool processing

More advanced training in literacy and numeracy in the Spanish language

Perhaps a cooperative for both production and marketing of handicrafts

Drug education programs, programs to stop drift to the city of Lima

Using the existing community organization, Amen suggests the creation of an arrangement called "community work time" which obligates each individual in the community to put in some time every week in the development of a community project. (The construction of a community center could be one such project.)

A design for such a community center is suggested on the next page.

The learning resources proposed for such a center are:

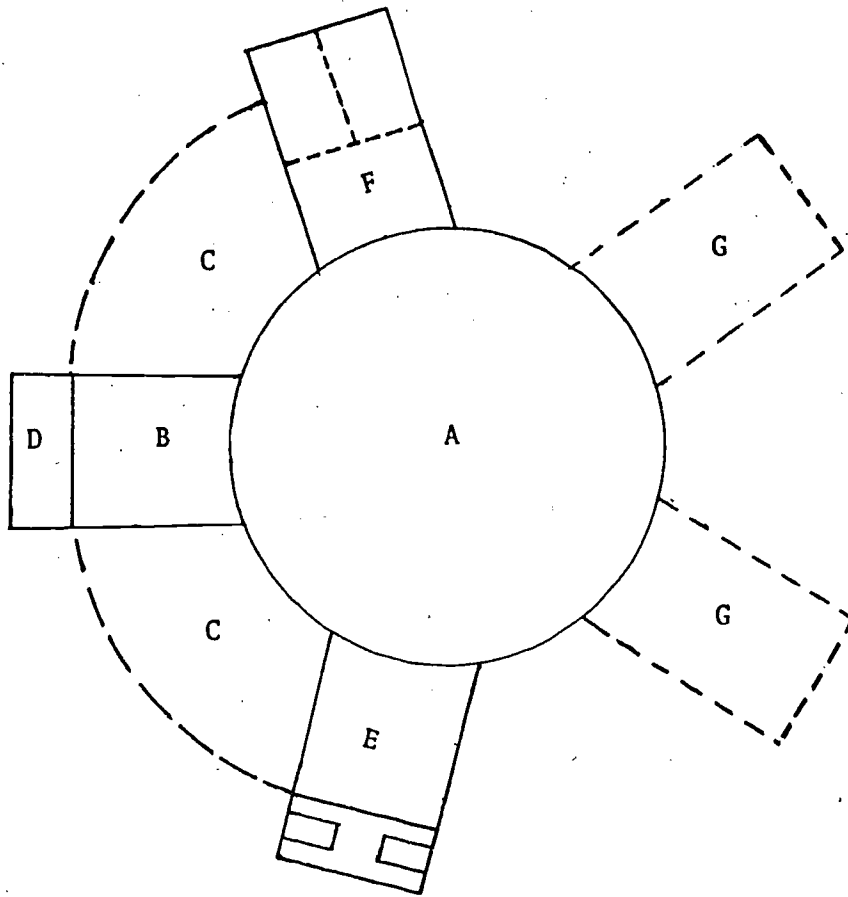

- A - Community meeting room including a small library and projection equipment
- B - Agricultural center
- C - Experimental vegetable and flower garden
- D - Tool storage room
- E - Medical clinic with a two-bed room for serious cases
- F - School, movable dividers make different divisions possible
- G - Other wings that may be added later

Figure 4. A community learning resources building and its component parts.

Agricultural machinery and tools  
radio sets  
demonstration materials and specimens  
picture sets and learning materials kits.

Once again, the usefulness of the "group" is emphasised. Also, a back up system is assumed at the regional (district) and national levels. A regional center of some sort (DLRC) is expected to help by providing material inputs which only the government can provide. More importantly, the regional center is expected to provide help in training local cadres, marketing of goods and services produced in the community, and expert consultancies on all the various aspects of agriculture, animal husbandry, health, and management of agro-businesses. This same regional center, or one at the national level, is supposed to circulate instructional materials such as films and demonstration kits.

## IV

LEARNING RESOURCES FOR COMMUNITY EDUCATION:  
A MULTIMEDIA MEGA CENTER

For some readers, the second title of this section will have a familiar ring. In an earlier paper, I have proposed a multiframework mega model of community education for community action.<sup>1</sup> I now propose a multimedia mega center of learning resources as part of an overall instructional strategy for community education for community action. Any sensible institutional planning for a national system of community education will require that national resources be harnessed to provide instructional media support to the various community education programs in a developing country. This paper is an initial effort towards such institutional planning in the Third World countries that are, typically, economies of scarcities; and have, mostly, inadequate infrastructures of communication.

The dilemma exists but is possible to resolve

Earlier, we have been emphasising the need for local initiatives in community education. We suggested that community education programs should respond to local needs, be locally designed, and use folk media and existent patterns of communication and socialization. Now, on the other hand, we are talking of institutional planning at the national level for creating what we have called a multimedia mega center. Isn't that a contradiction? How can we produce instructional and communication messages in a centrally-located multimedia mega center to be meaningful to all those communities that we assert have their very own special communication needs? Isn't there

---

<sup>1</sup>H.S. Bhola, "Community Education for Community Action: A Multiframework Mega Model," a paper prepared for the USAID/San Jose State University project, Learning Resources Center-Based Community Education Systems (Project No. 598-15-670-573), 1977.

indeed a dilemma in the whole idea of centralized planning to generate local initiative? The dilemma, fortunately, may be more apparent than real.

Centralized planning, indeed, seems necessary to give any society a central purpose. This need not mean, of course, the enforcement of one dogmatic future. There is no reason why a society could not decide to have an open-ended future. But such an open-ended future may yet have to be planned. Centralized planning must indeed be undertaken to generate a movement within which local initiatives for community education for community action can take place. Also, as I have indicated in my mega model paper, the national purpose will have to be reinvented in each local community. This would mean that an open-ended developmental process would have to be generated in each community instead of imposing pre-designed development projects on powerless local communities. The institutional arrangements that are created at the national level to make progress towards these new directions, will have to take the form of enabling organizations, that enable local communities to invent their own means to developmental ends locally-invented. These central institutions must, in addition, supply the inputs that cannot be locally generated by individual communities for actualizing their developmental needs and aspirations.

However, this still may not answer the concern of some in regard to the production of general messages in a multimedia mega center in a central location that would yet serve the purposes of communicating meanings to local communities engaged in the satisfaction of specific, locally-determined needs. At first sight, this may even seem impossible to reconcile, but there are possibilities:

First, there are some messages that can be centrally produced because they are of general usefulness and might, therefore, be universally consumed within a society. Documentary films that interpret the national heritage to

The nation would be an obvious example of such general messages. The contributions of various social, ethnic and regional groups to the cultural, social or economic aspects of a society must be shared and brought to the attention of all the people by film and television. Again, the messages seeking to build a national identity; to create ethnic and racial harmony; to teach economic, social and scientific literacy; and to develop a skilled community can all be centrally produced.

Second, general messages can be so produced that those may lead to discussions of problems in specific local settings and to the invention of solutions unique to a community, or area. Our knowledge of instructional development processes and of message design can enable us to produce such messages.

Third, central facilities of a national multimedia mega center may be made available to groups to produce less than general messages and message systems -- messages that serve special client groups. Mass media technologies today have made it possible to specialize message making -- to produce special messages, for special publics, at small costs. In other words, centralized facilities may be used to produce community-specific messages on video tapes and film.

Fourth, a division of labor may be developed among the multimedia mega center and local and district community centers in regard to the production of materials. Multimedia instructional packages may be planned. Parts of these multimedia instructional packages may be produced at the mega center while other parts may be produced locally within the community and/or at the district learning resources center that serves such a community.

Institutional arrangements for  
a multimedia mega center

The institutional arrangements needed for developing an overall strategy for learning resources for community education will consist of two organizational mechanisms:

1. A fund for the learning society; and
2. A multimedia mega center.

The fund for the learning society will be a device for raising and holding funds for the establishment and promotion of all learning resource institutions in a country, for establishing general production and distribution policies and for the review of such policies on a continuous basis.

The multimedia mega center will start as a conglomerate including many different instructional media elements: (1) a non-projected materials unit that produces charts, posters, graphics, specimens, models and kits; (2) radio transmission with production facilities; (3) a documentary film production unit; (4) television production studios and transmission facilities; (5) a film unit for producing instructional films; (6) a textbook research unit for producing school books, as well as books for the new literate adults coming out of literacy classes; (7) a printing press with facilities to produce books, and multicolored charts, posters and other didactic materials; (8) a lending library for loan of books, films and tape recordings for the communities all over the country; and (9) a correspondence education bureau.

As development communication needs of the country expand and become more and more articulated and urgent; institutional experience is gained; and resources become available, different elements of this multimedia mega center may split from the mega center and become institutionalized as separate organizational entities. For instance, the radio element of the mega center may split to become a separate institution called the Public Radio Broadcasting System. A separate National Documentary Production Unit may



ome about. Television services, again, may separate to develop into a national Television Network with appropriate booster stations and cable distribution systems. Sometime, in the future, a separate Center for the production of Instructional Films may be created. Textbook production may separate to become a Textbook Research Bureau and a Center for Books for the new Reading Publics. The print shop in the mega center may leave to become National Printing Press with facilities for production of books as well as other pictorial materials. Library services may develop into a National Library System, a National Film Library and a Library of Tapes. What remains may become an Instructional Materials Center for a district level school system.

The elements of a multimedia mega center, showing a possible pattern of separation and independent institutionalization of various elements, is shown in Figure-5 on the next page.

policies on procurement of  
instructional materials

Part of the plans for the provision of instructional resources for community education for community action implied in the Fund and the Mega center above could be most easily subverted by improper policies in regard to the procurement and purchase of instructional materials for the center. The easiest way to kill such a center, forever, would be to import free, or at great cost, a whole library of films and documentary films from U.S.A., Canada and Europe. Similarly, books, charts, posters and models could be imported and the project for the provision of community education materials be forever doomed.

While equipment will have to be imported, as also some materials and raw stocks such as film and even paper, instructional materials should be imported from outside almost never, or only in the most exceptional cases.

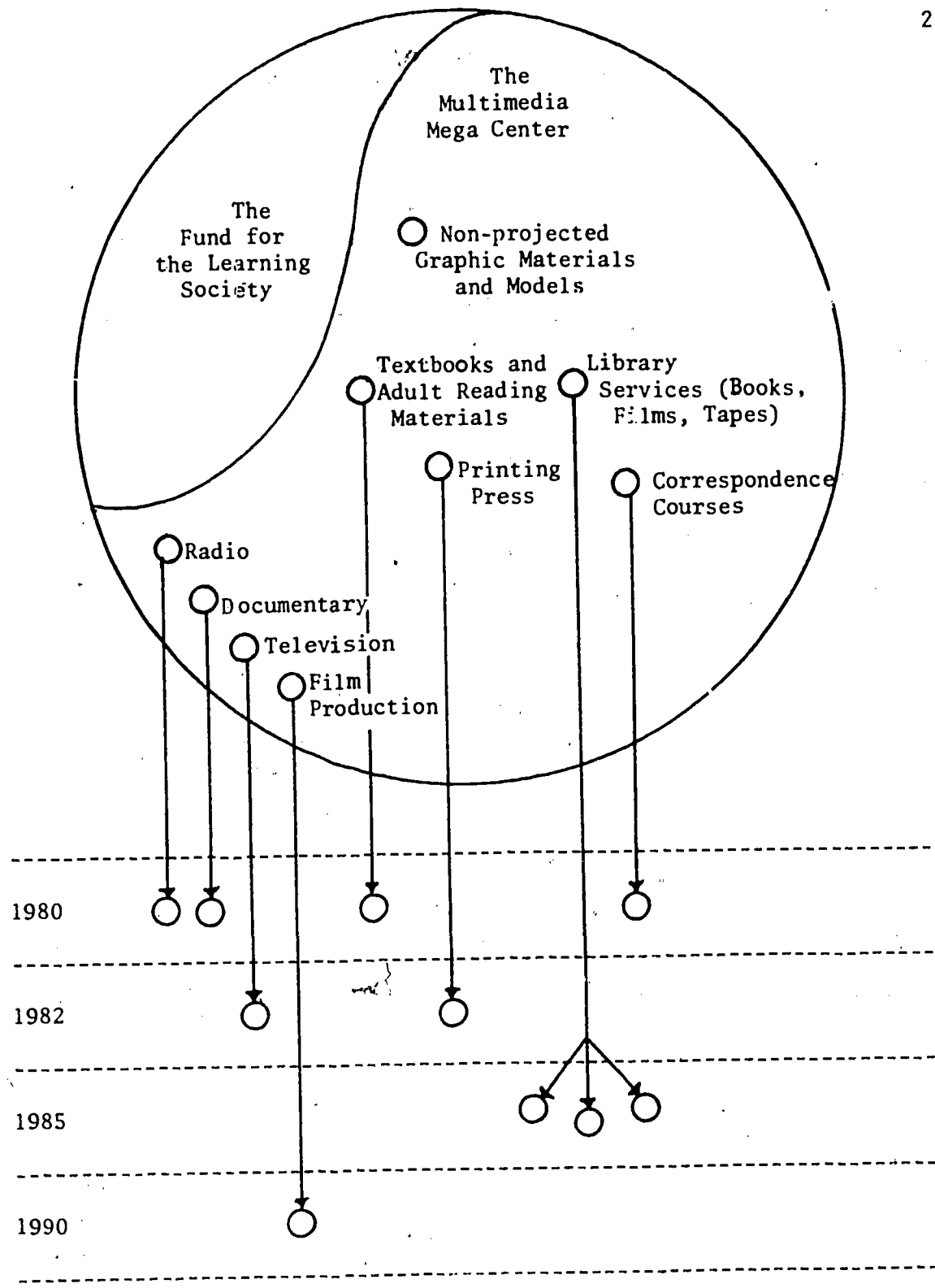

Figure-5. The elements of a multimedia mega center, showing a possible pattern of separation and independent institutionalization of various elements.

When such materials must be imported or are received as gifts from outside governments, these must always be adapted (by editing, dubbing or adding new sound tracks) before these are released to the communities within a different socio-economic and cultural situation. This would mean that practically all of the material in such a Mega Center, and distributed by it, would have been locally or regionally produced.

## SPECIAL PROJECTS: A PART OF THE WHOLE

It would not be difficult to come across in any developing country, special projects that have been designed to serve immediate community education needs or the needs of learning materials for community education programs. Quite often special projects arise from the need of leadership for crisis management or to make a demonstration to the public that the government is interested in a particular problem, in a particular region, for a particular ethnic group or social class. Such special projects may sometimes be described as demonstration projects, or pilot projects or may be pretentiously described as experimental projects. These special projects may have national scope or be oriented to the region, district or a community. Most have been known to languish after the first flush of enthusiasm and fuss!

Criteria for establishing special projects

Some criteria can be established for the design and implementation of special projects:

1. Special projects should meet important and immediate needs of a community or a region.
2. Special projects must be conceived in a system perspective that responds to national vision, national resources and structural possibilities in the short and the long term. In other words, decisions should be made at the time of planning a special project as to how it would fit into the total prospective plans of the country, how the special project will expand and in what phases, and how the various institutional arrangements will be handled.
3. Special projects must play a generative role in the actualization of the

ultimate national vision in regard to community education for community action and in regard to the provision of instructional resources needed for the implementation of that national vision. Thus, the special project would be the first crystal that starts the process of social/institutional crystalization resulting ultimately in a national system of community education supported by a system of learning resources for a learning society.

Examples of special projects

Examples of special projects are easy to gather from the literature of community education for community action in Latin America and elsewhere. Some of these projects have succeeded beyond expectation and some have failed, perhaps, because they did or did not think of future plans as they implemented present action. Here are some cases:

National level	ACPO, SENA
Regional level	Cultural missions
District level	Service centers
Local level	Community education centers

Many of these special projects, actually at work in different countries, are inter-level projects such as Leadership-Followership communication through video-tapes in Canada and in Tanzania; radio broadcasting with radio forums in India, etc.

## DESIGNING IN CONTEXT, BY OBJECTIVE

It would not be redundant to remind ourselves that the design of multimedia mega systems and centers for a learning society and development of the community education systems that are created to serve underprivileged communities will admit of many and varied solutions. Prospective planning will have to be specific to each cultural and socio-political reality. Systems will have to be designed in context and beginning steps will have to relate to immediate objectives.

Two roads to the same destination

In regard to the creation of learning resource systems that can effectively serve the needs of community education for community action, one can use two different roads and yet reach the same destination. For example, one could focus on building a national system of learning resources; and, secondarily develop ancillary programs whereby these materials are used in different ways, and in different settings, to serve different community information needs. Such a system over the years could lead to what is represented in Figure-6. Learning resources of various kinds (films, radio, TV, books, graphics, etc.) are located within appropriate institutions at various levels (national, regional, district and community) to come together into a comprehensive system of learning resources for a learning society.

One could take another road to the same destination. One could, that is, build a national system for the delivery of community education for community action to all communities in the nation; and at each level, and within various appropriate institutions of community education, could locate

learning resource components to serve special institutional purposes at that level. Figure-7 suggests such a national network of community education from the national through regional and district to the community level with learning resource components built into the community education delivery system at all its various levels.

Finally, some countries would be able to follow neither the one nor the other of approaches discussed above in a comprehensive way so as to cover the nation and thus to serve all communities. They may, as have been suggested earlier, want to start special projects as represented in Figure-8. Such special projects may often become the foundation stone for a comprehensive learning resources system if organizational mechanisms can be created that would in the immediate run serve the purposes of all the special projects and later serve other clients in the society as shown in Figure-9.

### Conclusions

Planning is a process that deals with the future; and the future, by definition, is unknown. Knowing the present helps to understand the future and, therefore, to plan for it. However, the present is not experienced by each community in the same way that by planning for one we could plan for all. It is for this reason, therefore, that planning can seldom give a particular community the prescription for its development. All a planning exercise of the present kind can contribute is to lay bare the calculus of means and ends, marshall all the variables, and help participants engage self-consciously in a process of progressive focussing of general ideas to their specific conditions -- to invent solutions uniquely their own.

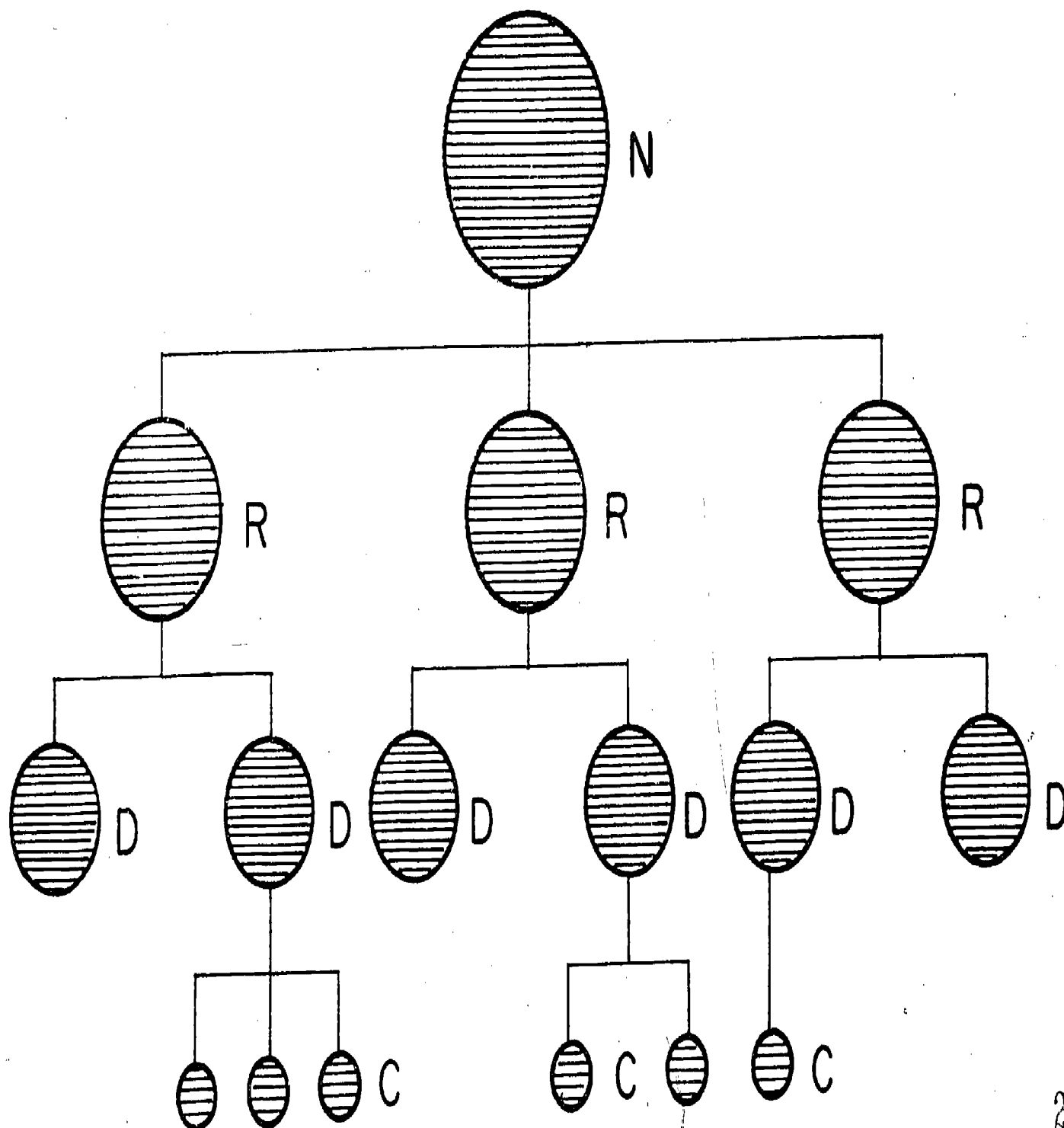

Figure-6. Appropriate learning resources in various institutions at various levels, resulting in a learning resources system for a learning society.

251

252

241



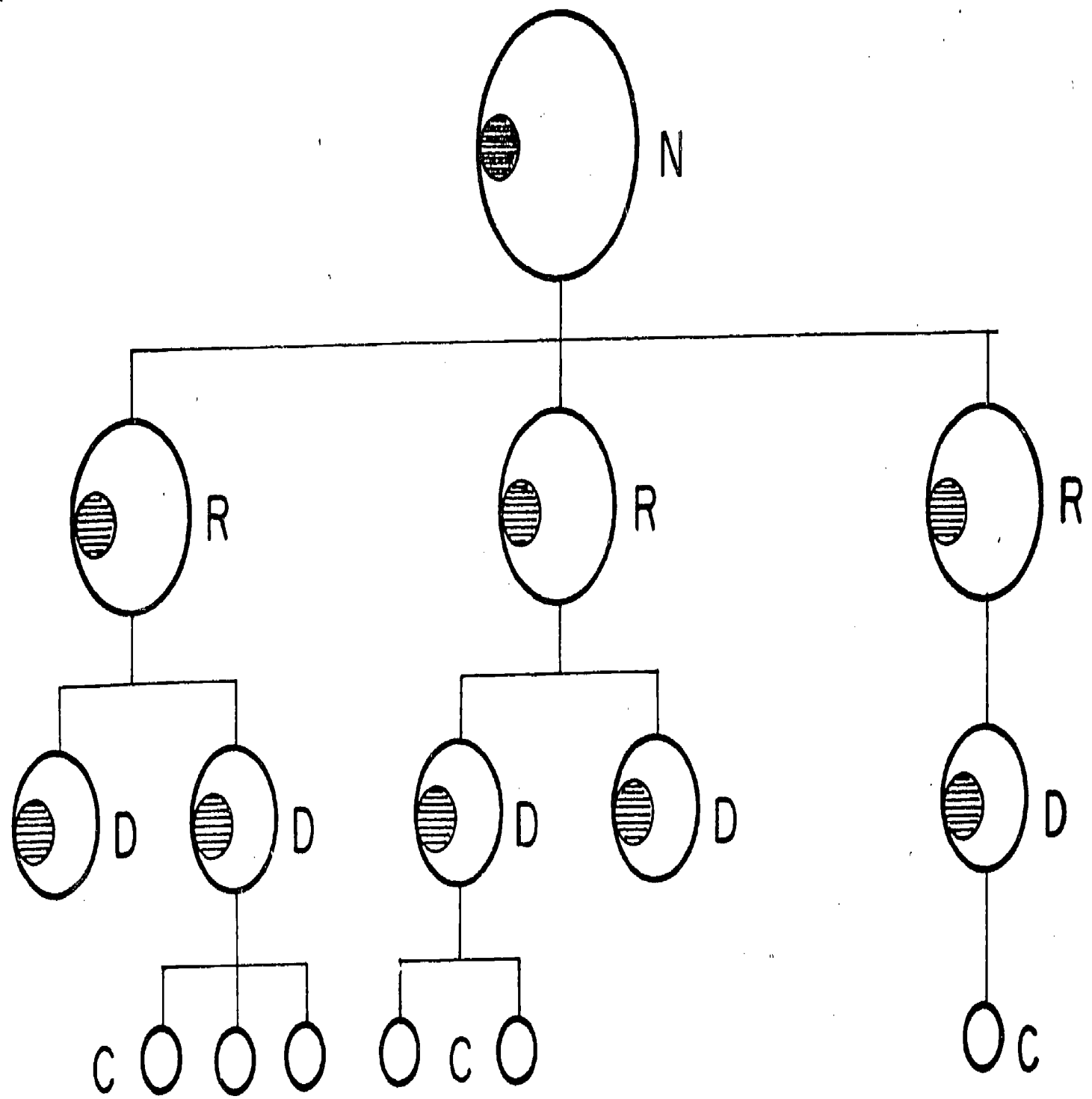

-36-

Figure-7. A comprehensive, national system for the delivery of community education for community action, with learning resources components built into the system at various levels.

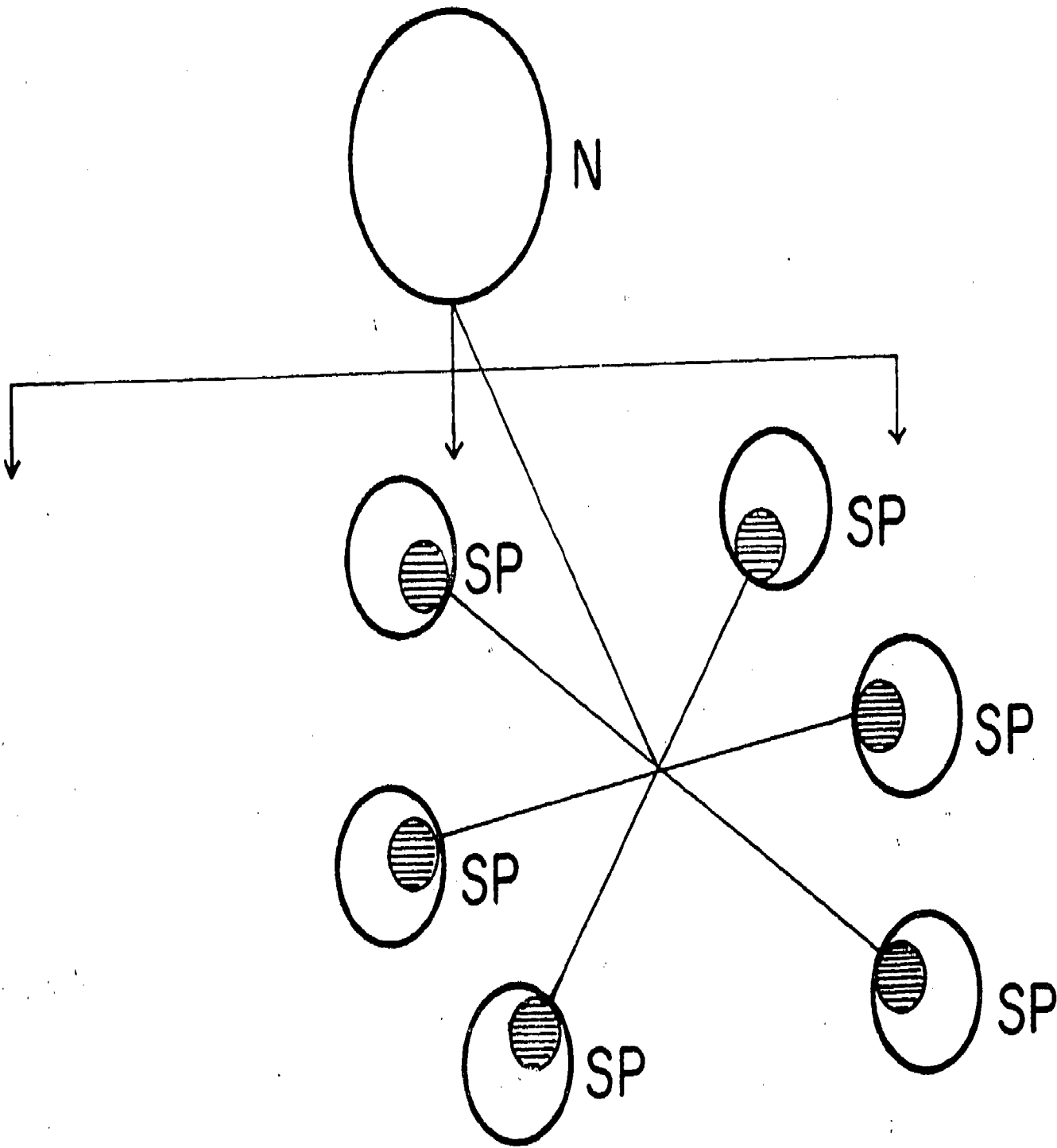

255

Figure-8. A network of community centers under a special project, each self-contained in terms of learning resources facilities.

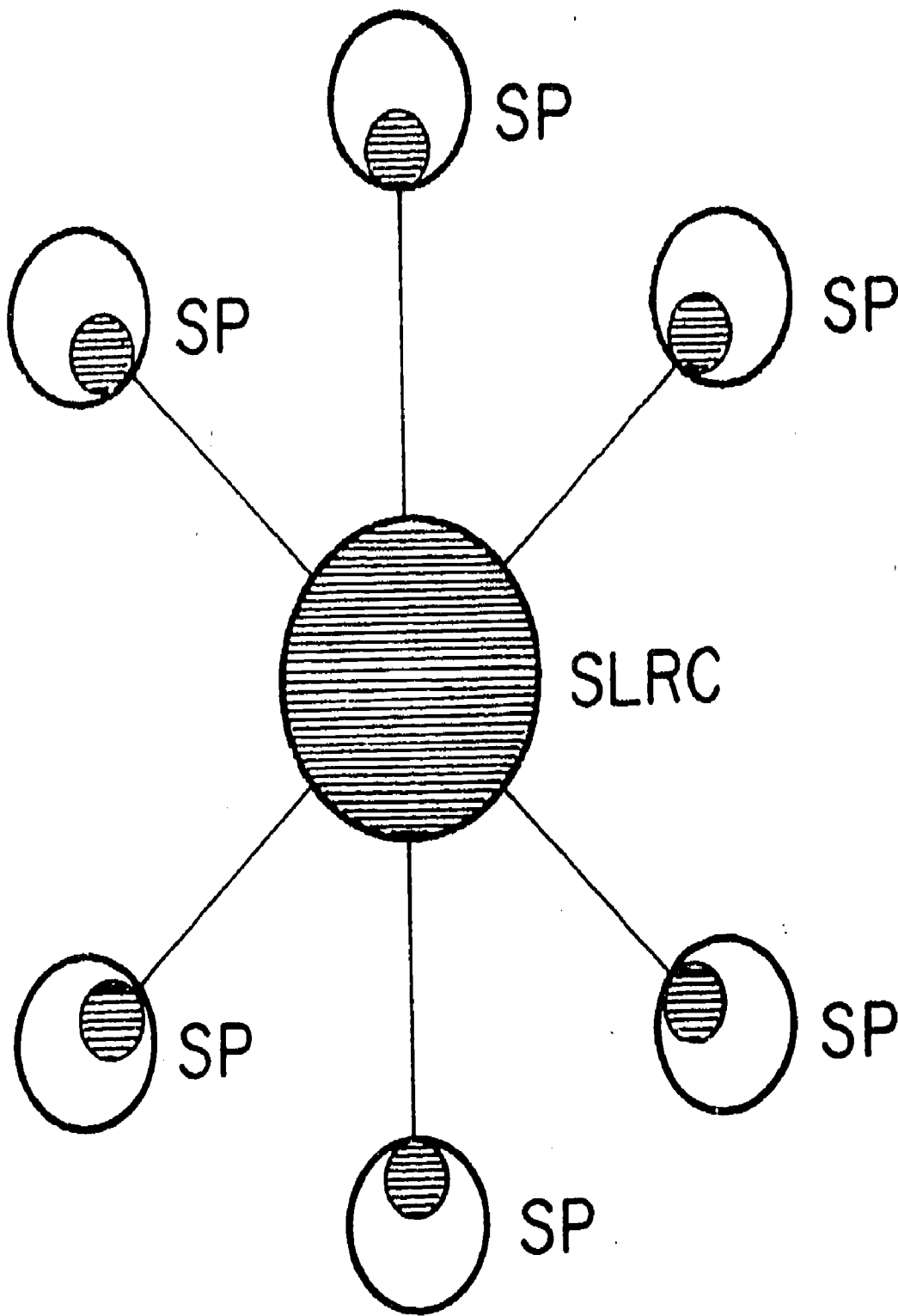

Figure-9. Community centers under a special project being served from a central learning resources center. Such a central learning resources center could at some later time begin to serve clients other than those served by the special project.

244



APPENDIX G

GERMAN FOUNDATION FOR INTERNATIONAL DEVELOPMENT

BONN / FEDERAL REPUBLIC OF GERMANY

and

DEPARTMENT OF ADULT EDUCATION, MINISTRY OF NATIONAL EDUCATION

DAR-ES-SALAAM / UNITED REPUBLIC OF TANZANIA

WORKSHOP ON CURRICULUM AND PROGRAM DEVELOPMENT

FOR POST-LITERACY STAGES

2-14 June, 1980

Project Description

KF-22-10-80ex

20-2-1980

WORKSHOP ON CURRICULUM AND PROGRAM DEVELOPMENT  
FOR POST-LITERACY STAGES

INTRODUCTION

After literacy, What? The question has troubled both the new literates and the organizers of literacy programs. Too often, costly efforts have gone to waste as new literates have relapsed into illiteracy for lack of books to read. Newly literate men and women have felt frustrated when they could not make functional uses of literacy in their daily lives.

The problems of post-literacy stages can be viewed in two parts:

(a) Read what? and (b) Read to what purpose? Fortunately, the first question has received some attention from literacy workers. All over the world, literacy workers have sought to determine the reading interests of new literates; to train authors to write especially for new literate adults; and to get books and newspapers for these new readers published and distributed. However, the second question, "Read to what purpose?" has not always been squarely faced. Where the new literates live, there are often no opportunities to make functional use of literacy. Existing political, social and economic structures and arrangements do not always invite participation or require functional uses of literacy skills. Herein lies a challenge that literacy workers must face. They must understand the structural blocks to functional uses of literacy in communities and they must learn to employ structural strategies in their approaches to programming in the post-literacy stages.

To deal comprehensively with the problems of post-literacy stages in our overall literacy policies and plans in the 1980s, we must include the following elements:

- a) production and distribution of reading materials for new literates,
- b) provision of "second chance" formal education for those who want it,
- c) creating skills for the use of information sources and bringing

- opportunities for the enjoyment of culture,
- d) development of training programs that link literacy with social, economic and political functions, and
  - e) creating delivery systems and institutional arrangements that make all of the preceding possible in systematic ways.

#### GENERAL OBJECTIVES

At this time in Tanzania, a review of post-literacy programs in action and an examination of future needs and possible approaches would be extremely useful not only for the current Tanzanian program and for Tanzanian educators but also for literacy workers and programs elsewhere.

The general objectives of the "Workshop on Curriculum and Program Development for Post-Literacy Stages" will be: (i) to attempt a comprehensive conceptualization of the needs for programs and curricula in the post-literacy stages; (ii) to review the experiences in post-literacy curriculum and program development in Tanzania and elsewhere; and, (iii) in terms of the existing needs and possibilities, to project innovative approaches to post-literacy curricula and programs in Tanzania in the 1980s.

#### SPECIFIC OBJECTIVES

The specific objectives of the workshop will be to enable participants:

- i) To define needs of post-literacy stages comprehensively to include
  - (a) retention of literacy skills, (b) continuing education, both formal and nonformal, and (c) program design to link literacy with social, economic and political functions.
- ii) To assess learning and program needs in terms of national agendas; and to make diagnoses of learning and program needs at the community level.
- iii) To separate program and curricular needs that can be met through local initiatives, from those that must be met at some higher levels of decision-

making and planning.

- iv) To learn the skills of curriculum development "by objective" to meet specific learning needs, of specific groups, in specific settings.
- v) To understand social organization and indigenous institutions and to harmonize the roles of indigenous and formal institutions in development processes.
- vi) To interpret programs and curricula designed nationally or regionally to adult learners in the communities; and to share with national and regional planners and programmers local experiences with national promise.
- vii) To implement programs and strategies that assist retention of literacy and promote the reading habit.
- viii) To understand the problems of preparing "second chance" curricula for those wanting to continue with their formal or nonformal education.
- ix) To provide counselling and guidance to youth and adults for choosing between programs and curricula, explaining relative advantages and disadvantages, in both personal and collective terms.
- x) To map linkages between literacy and its social, economic and political functions; and to collaborate with extension workers and educators in agriculture, cooperatives, technical and vocational education, trade union education and health and family education in the design of suitable post-literacy programs and curricula.

#### TOPICS TO BE COVERED

The following topics may be covered:

1. The concept of functional literacy; and a general conceptualization of learning needs in the post-literacy stages, if literacy has to play a significant role in development.
2. An accounting of the constituencies and client groups that must be served in post-literacy stages; and a look at the types of programs and curricula that must be provided to these various groups.

3. The problem of retention and how to avoid relapse into illiteracy.
4. Curriculum development models and methods and their application to problems of curriculum development in the post-literacy stages.
5. Principles of counselling and guidance; and the problems and challenges of counselling new literate adults in rural communities of the Third World.
6. Program design and development to build linkages between literacy and social, economic and political functions.
7. Review of international experiences in post-literacy program and curriculum development.
8. Social organization and the role of indigenous institutions; and problems of building institutions to fulfill new developmental needs of communities.
9. Innovative curriculum and program design in national contexts; and discussion of multi-purpose learning institutions, such as, the Learning Resource Centers (LRC's), Polyvalent Centers, etc.

#### WORKSHOP DESIGN

The detailed program for this workshop, as in the case of one earlier workshop on evaluation of functional literacy programs held in Mwanza, Tanzania during December 1976, will be determined in collaboration with the workshop participants, to suit their particular needs and to reflect the development problems and opportunities in Tanzania as seen by Tanzanian educators themselves. Therefore, this Project Description merely evidences the organizers' thinking and advanced preparation for the workshop. The workshop objectives, general and specific, will be negotiated with the participants to provide them with the opportunity to make the workshop their workshop and to fit their needs, expectations and realities. Indeed, questions of emphasis, treatment, sequence and application will be decided only after the participants have met to discuss the purposes and procedures of the workshop.



## INSTRUCTIONAL METHODS

A variety of instructional methods will be used including plenary sessions for lectures and discussion, guided group work, individual consultancies and reading assignments, case studies of post-literacy projects and curricula, commissions to design future curricula, programs and delivery systems, and practicums for applications of concepts and skills learned in the workshop.

## WORKSHOP DOCUMENTATION

When workshops are participatively designed, participants must choose. But choosing also means leaving out. Some significant concepts, issues, approaches and skills in the field of interest may thus be left out completely or may receive somewhat superficial attention. This problem is remedied through a judicious selection of Workshop Documentation which is often especially commissioned by the German Foundation for International Development by way of preparation for these workshops. Workshop Documentation, typically, presents a comprehensive and didactic treatment of the subject of the workshop and puts in a larger perspective, the current, selective interests of the workshop participants. This documentation, produced in the form of handbooks is something that participants can return to, to review their workshop experiences or to pursue issues and interests on their own.

The two basic documents for this workshop will be:

1. Curriculum Development for Functional Literacy and Nonformal Education, and
2. Curriculum and Program Development for Post-Literacy Stages.

Handbooks from the series of training monographs, Literacy in Development (published by Hulton for the International Institute for Adult Literacy Methods) and Government of Tanzania documentation related to literacy, and post-literacy programs will also be available to workshop participants.

## PARTICIPANTS

Participants will be Tanzanian decision makers in adult education and literacy, particularly, curriculum and program specialists, correspondence educators, textbook and materials writers, media specialists, broadcasters and evaluators. Some participants may come from labor unions, political education, women education, agriculture and cooperatives, and health education--areas with which literacy workers must relate to develop effective post-literacy programs.

Two participants from Ethiopia and/or Mozambique may also attend. The total number of full-time participants including faculty will be no more than 25.

## FACULTY RESOURCES

The role of the workshop faculty will be essentially that of facilitation and provision of technical resources. Extensive use will be made of workshop groups for both discussion and practical exercises. A faculty member will be available to each working group as a resource person. The leadership for the conduct of the workshop will rest with the participants and committees they appoint.

The faculty will be led by Professor H.S. Bhola of the School of Education, Indiana University. Three tutors from Tanzania will be nominated to the faculty by the Government of Tanzania. Dr. Josef Muller of the DSE will also be part of the faculty group.

## EVALUATION

Evaluation will be built into the proceedings of the workshop. Its sole purpose will be to provide feedback for the continued improvement of the workshop on a day-to-day basis. There will be no evaluation of individual performances.